

# ASSEMBLY INSTRUCTIONS

Air filtration kit for 3D printer enclosures

- ☒ ALVEOONE-R free stand
- ☒ ALVEOONE wall mounted

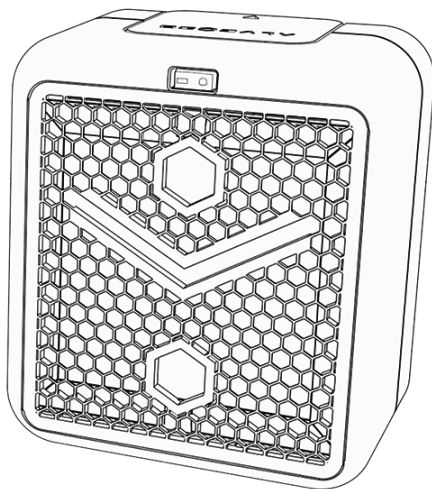
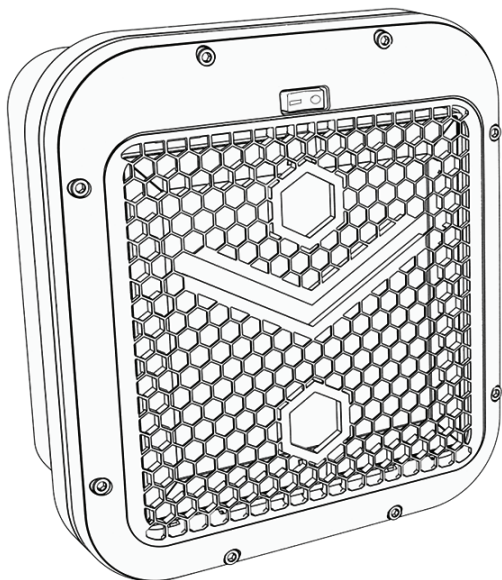

Find all our assembly tutorials on

[www.alveo3d.com/en/assembly/](http://www.alveo3d.com/en/assembly/)

# ELEMENTS PROVIDED

## Elements included in the alveoONE kit

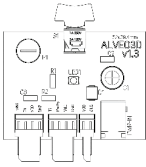

- Electronic board v1



- Power supply 24 Volts



- Fan ALHP2425-H8

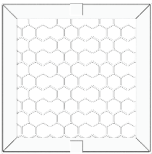

- Filter P3D



- Cylindrical screw M3 25mm x8

- Hexagonal nut M3 x8



- Cylindrical screw M4 40mm x4

- Hexagonal nut M4 x4



- EPDM sealing cord 50cm x2



- Non slip pad x4



- Sealed plastic bag (for used filter)

## TOOLS NEEDED

### Not provided tools needed to assembly the kit



- Hexagonal key 2.5 mm  
(for screw M3 & M4)

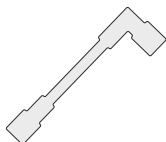

- 6 point pipe wrenches 7mm  
(for nut M4)



- Cutters

### Not provided recommended tools to replace the filter



- Gloves



- Mask FFP2 or better

## SAFETY

### Read all instructions before using.

- This filtration kit use a very powerful fan. Turn it on only after you are done assembly with the printed protection fan grid. Ignoring these instructions can cause injuries.
- Please use recommended electrical voltages to power electronic board, as indicated in the assembly instructions to prevent damage.
- Do not touch the electronic board in operation.
- Be sure that the installation of the filterbox in your enclosure will not interfere with the proper functioning of your 3D printers.
- Filter operational range 0-60°C max  
Optimal working temperature 0-40°C
- AlveoONE box operational range :  
ABS / PETG 0-80°C max  
PLA 0-50°C max

# INSTALLATION RECOMMENDATION

**You must print all parts to assembly the kit properly. You can find all STL files in the confirmation mail after purchase or download it on this link :**

**<https://www.alveo3d.com/en/download-alveoone/>**

## Wall mounted

Wall mounted type requires bespoke cutting to size following the cutting template: template you can print from the STL file or following the blueprint on page 6.

alveo**ONE** can be mounted on all panel thicknesses. The provided screws will be for panel thickness from 1 to 11 mm. if you have a thicker panel, you must use longer M3 screws.

Wall mounted kit requires the air intakes, it is dedicated to non air-tight 3D printer enclosure. We recommend to have the air intake surface between 5% to 25% smaller than the filter outlet (120mmx120mm) about 100 cm<sup>2</sup>.

That difference can guarantee a slight underpressure inside the enclosure and avoid airleaks from your enclosure. Every little spaces in your enclosure need to included when you measure the air intake surface. You can also check if you can feel the air suction.

We recommend to place alveo**ONE** on the opposite side of the air intakes.

## Free stand

The free stand kit requires an air-tight 3D printer enclosure in order to be the most efficient possible.

alveo**ONE-R** air flow shall be parallel to the 3D printer to avoid harmful interference with your printing and to improve an homogeneous air suction.

# WALL MOUNTED KIT : ALVEOONE

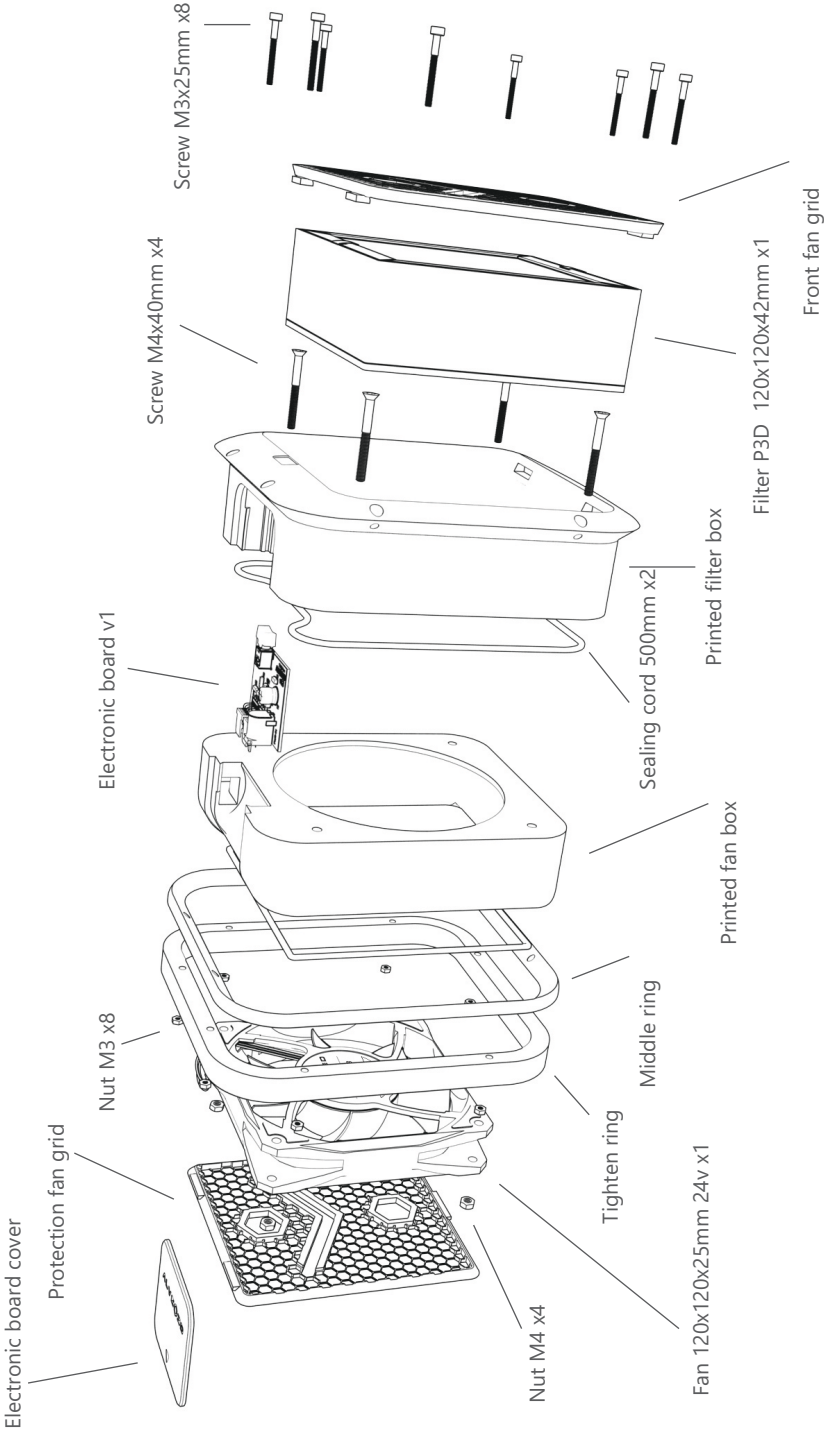

# FREE STAND KIT : ALVEOONE-R

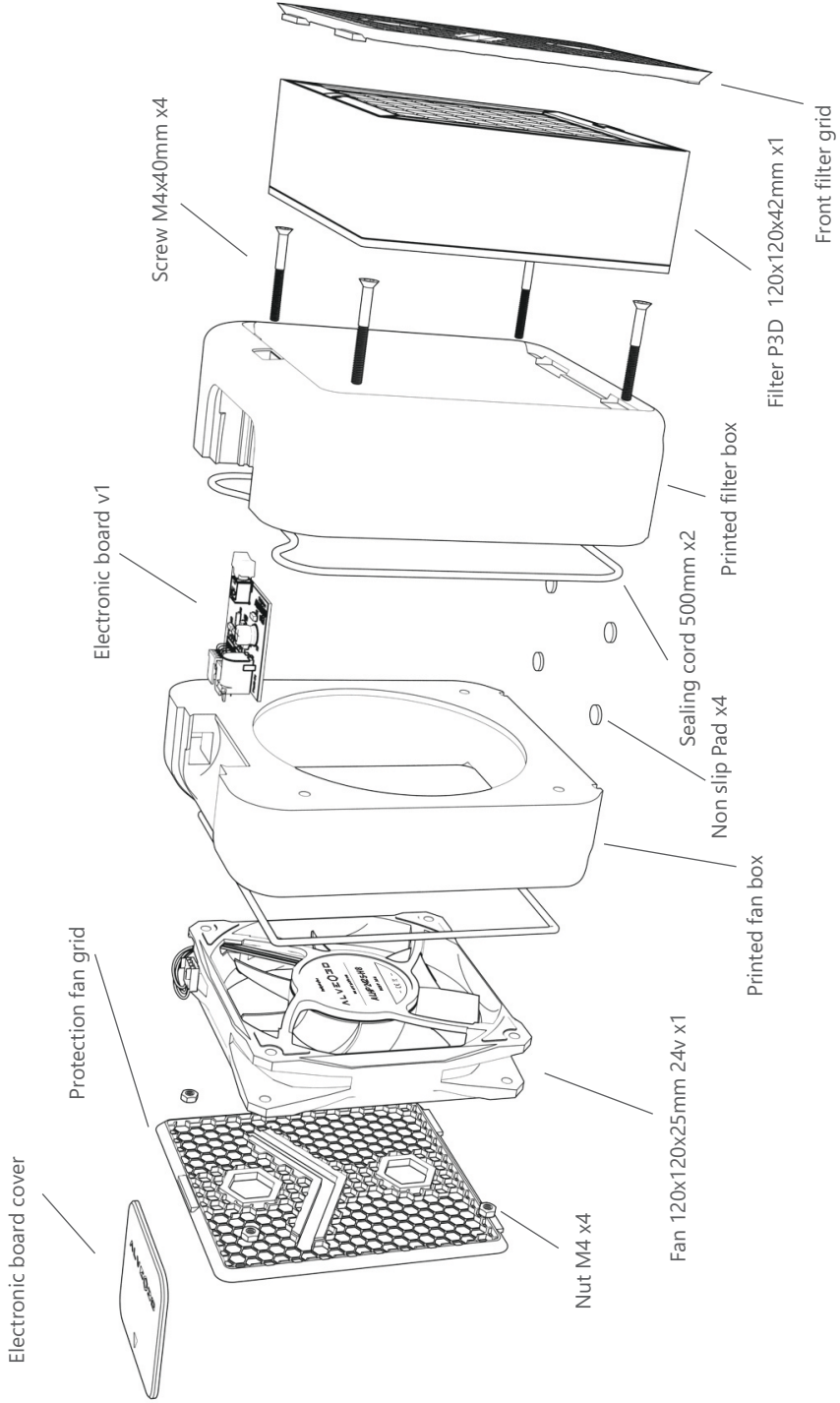

# ELECTRONIC BOARD V1

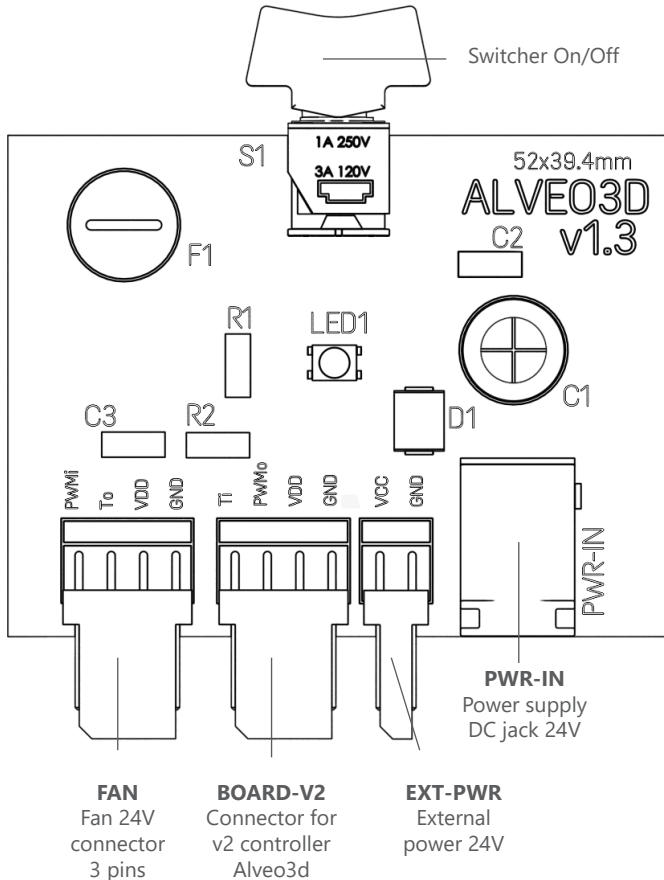

## How it works

Electronic board power supply input can be done :

- with the 24V power supply provided in the kit, just plug it into PWR\_INPUT
- with an external 24V power supply via the connector called EXT\_PWR. In this case the external power supply will control the board and not the switcher.

ALVEO3D designed an extended V2 controller board (a remote control available on our website) fully compatible with the V1 electronic board, if you own the board v1.3 or more.

To used to V2 controller board, you just need to plug the V2 board.



## STEP 1 - PANEL CUT-OUT

Kit concerned :

- ALVEOONE-R free stand
- ALVEOONE wall mounted

Choose the best position for the filterbox and trim the panel following :  
- the printable cutting template - watch our tutorial : [www.alveo3d.com/en/assembly/](http://www.alveo3d.com/en/assembly/)  
- or use the printer drawing find below. We also have attached a real sized drawing in your package.

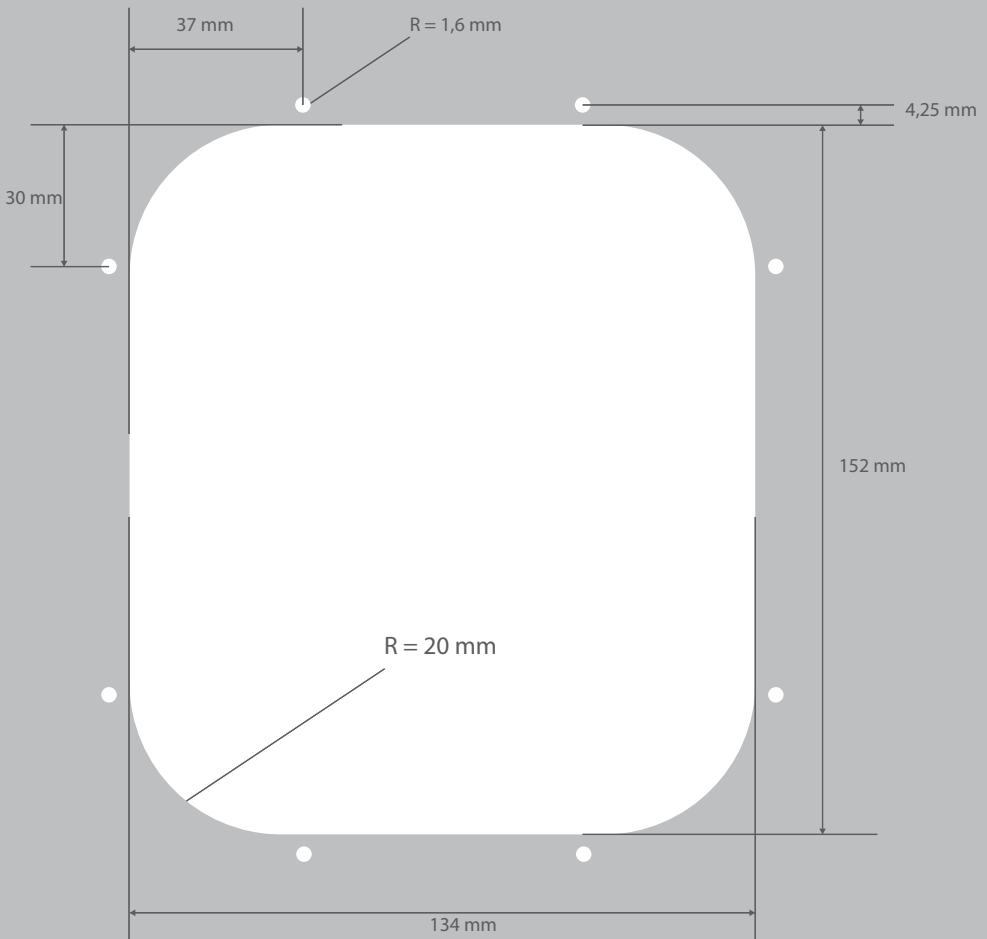

## STEP 2 - ELECTRONIC BOARD POSITIONING

Kit concerned :

- ☒ ALVEOONE-R free stand
- ☒ ALVEOONE wall mounted

**Our design allows the electronic board to be mounted without screws**

Slide the board on the end of rails.

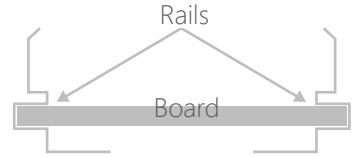
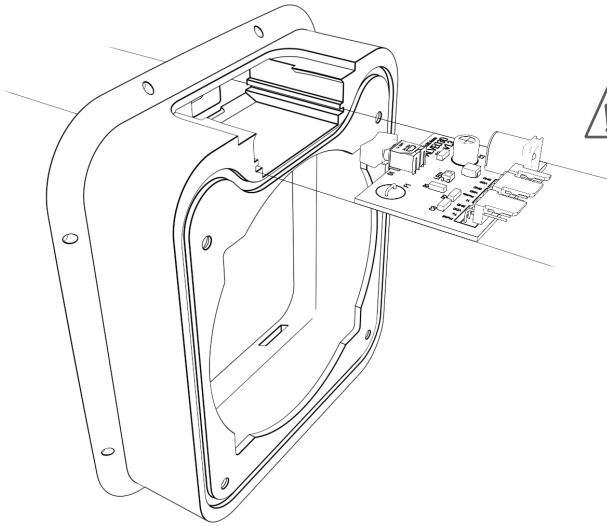

Switcher first, push the board inside the rails. It must be easy, if you feel you need to force to put the board to the end, you should make the rails bigger with a file.

The electronic board must be hold on the rails and exceed the printed surface. if the board is not completly in the rails, you need to clean them.

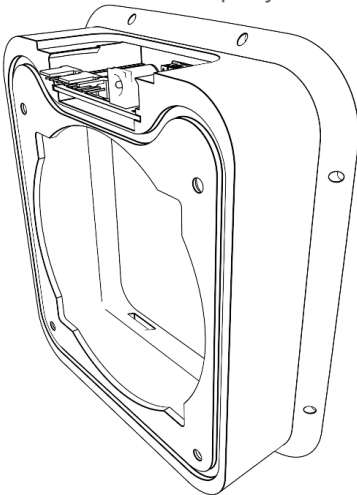

Check the switch button, not constraints must be applied on it. Switch on/off must be easy.

## STEP 3 - POSITIONING SEALING CORDS

Kit concerned :

- ☒ ALVEOONE-R free stand
- ☒ ALVEOONE wall mounted

Insert the sealing cord in the groove on the printer filter part.  
Cut off the extra cord and ensure to get sealing cord all over the groove (not free space). For the next steps make sure the sealing cord stays in position.

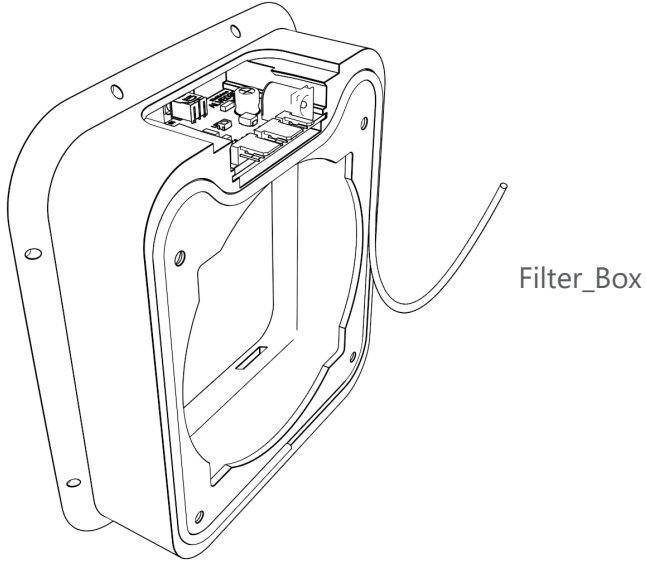

Insert the second sealing cord in the groove on the printer fan part.  
Cut off the extra cord and ensure to get sealing cord all over the groove (not free space). For the next steps make sure the sealing cord stays in position.

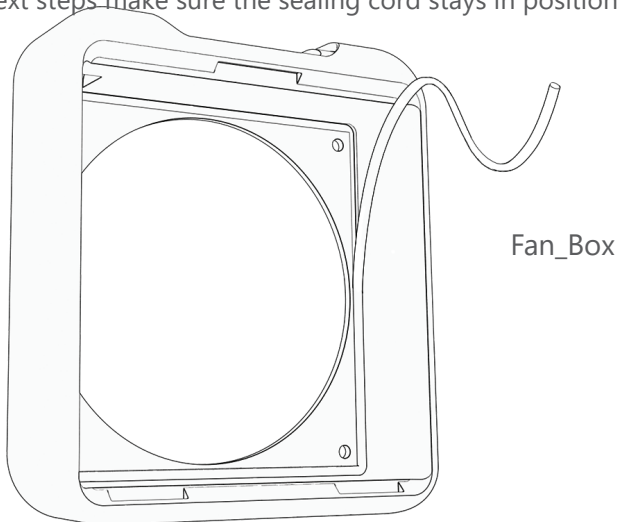

## STEP 4 - FAN POSITIONING

Kit concerned :

- ☒ ALVEOONE-R free stand
- ☒ ALVEOONE wall mounted

Insert the fan cable into fan box duct, remove properly the printed supports.

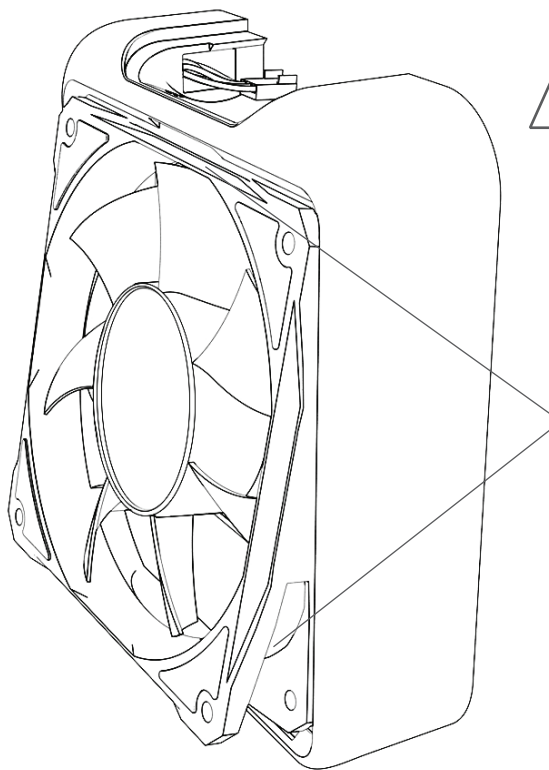

Make sure the fan label is oriented towards the filter side.

Slightly tilt the fan as the drawing to ease its installation in the printed fan part.



Be sure you do not clamp the wires during the assembly process.

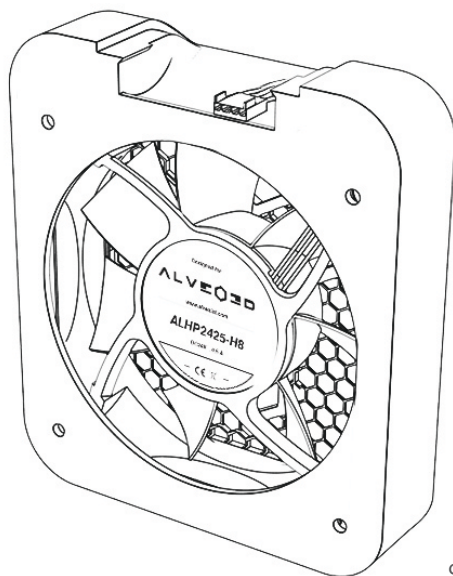

## STEP 5 - MAIN PARTS FIXATION

Kit concerned :

- ☒ ALVEOONE-R free stand
- ☒ ALVEOONE wall mounted

Position the filter printed part in front of the fan printed part to match drill holes from all three parts (printed filter part + printed fan part + fan) .

With the M4x40 mm screws and M4 nuts you can now assemble both printed parts with the fan. Tighten the screws enough to slightly compress the sealing cords.

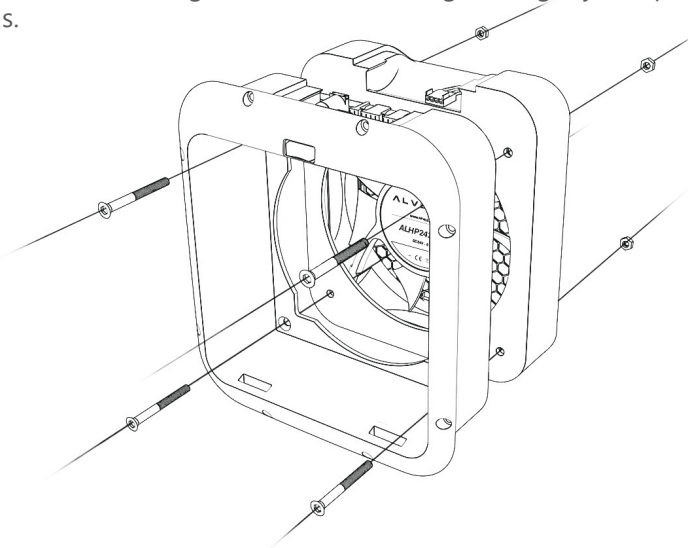

Connect fan wires to the electronic board on the 4 pins connector called FAN. Follow the drawing below.

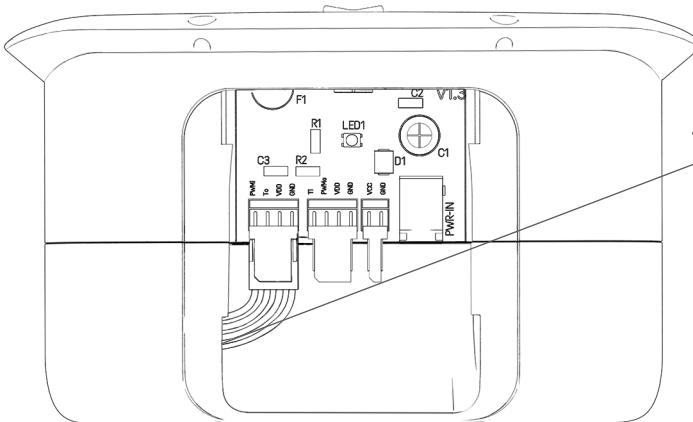

You can put the extra wires into the duct.

## STEP 6 - POSITIONING MIDDLE RING

Kit concerned :

- ALVEOONE-R free stand
- ALVEOONE wall mounted

Put the middle ring to the inclined surface on the printed filter part.



Middle\_Ring

## STEP 7 - TIGHTENING RING PREPARATION

Kit concerned :

- ALVEOONE-R free stand
- ALVEOONE wall mounted

Put all nuts in nut holes in the tightening ring.

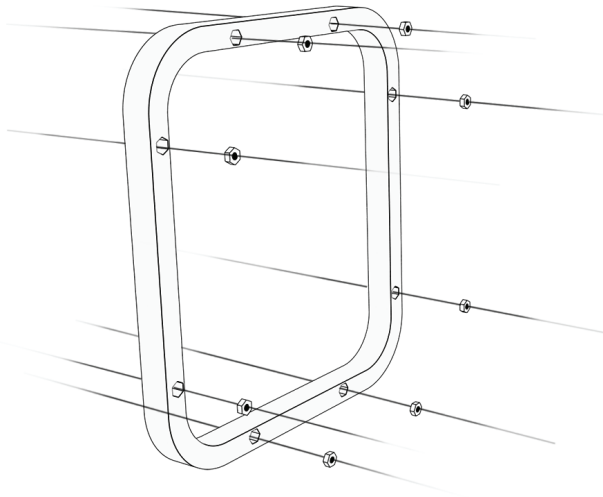

if needed, use a clamp to push nuts in their holes.

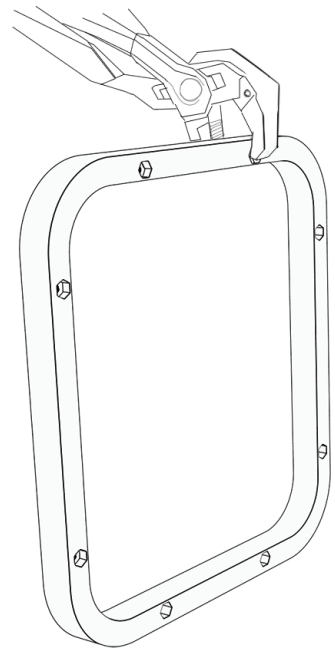

Tightening\_Ring



**Push every nuts to the end of holes following the nut shape. it will help you for step 8.**

## STEP 8 - ASSEMBLING WALL MOUNTED BOX

Kit concerned :

- ALVEOONE-R free stand
- ALVEOONE wall mounted

Place the filterbox (alveoONE) on the trimmed panel.

Put the tighten ring from the back of the filterbox.

Tighten the 8 M3 screws.

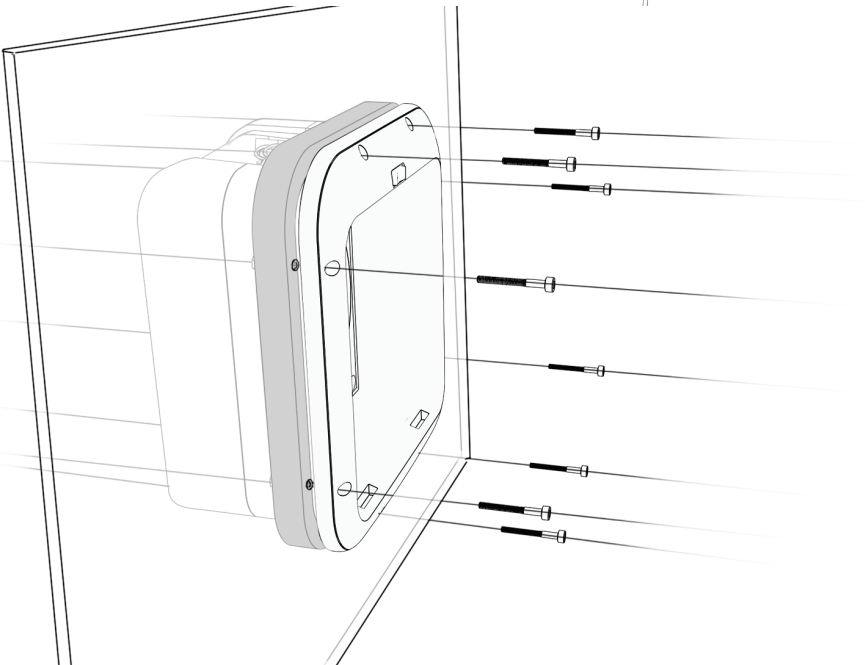
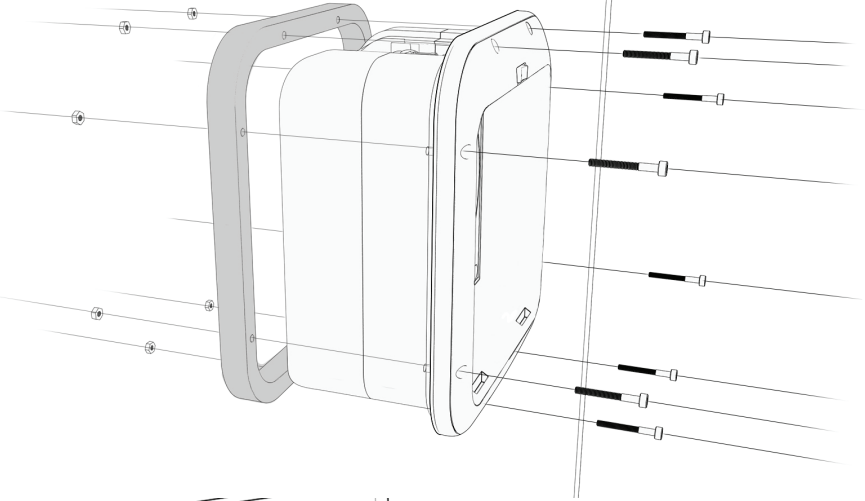



## STEP 9 - FILTER

Kit concerned :

- ☒ ALVEOONE-R free stand
- ☒ ALVEOONE wall mounted

Place the activated carbon black side toward the outside and the white HEPA side toward the fan.

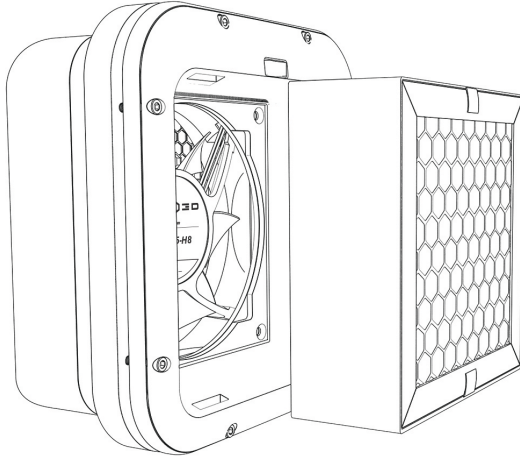

Put the filter in the printed filter box to bottom by pressing on the black frame only.

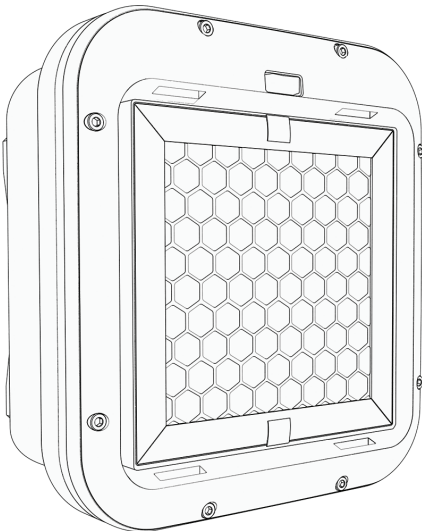

The white little handles on activated carbon side can help you to extract the filter when you replace it.

## STEP 10 - GRID

Kit concerned :

- ☒ ALVEOONE-R free stand
- ☒ ALVEOONE wall mounted

Clip the fan protection grid, the two big honeycombs and the flexibility of the material can help.



Fan\_Door

Clip the front grid to protect the filter and to kit the filter in the proper place.



The front grid will keep the filter pushed to avoid airleaks and ensure a better efficiency. Keep it in place.

If the grid does not fit perfectly with the shape of the filterbox, clean the lugs on the grid with a file or sandpaper

Filter\_Door

## STEP 11 - NON-SLIP PAD

Kit concerned :

- ALVEONE-R free stand
- ALVEOONE wall mouted

Put the non slip pad in the groove of the back of the filtebox.

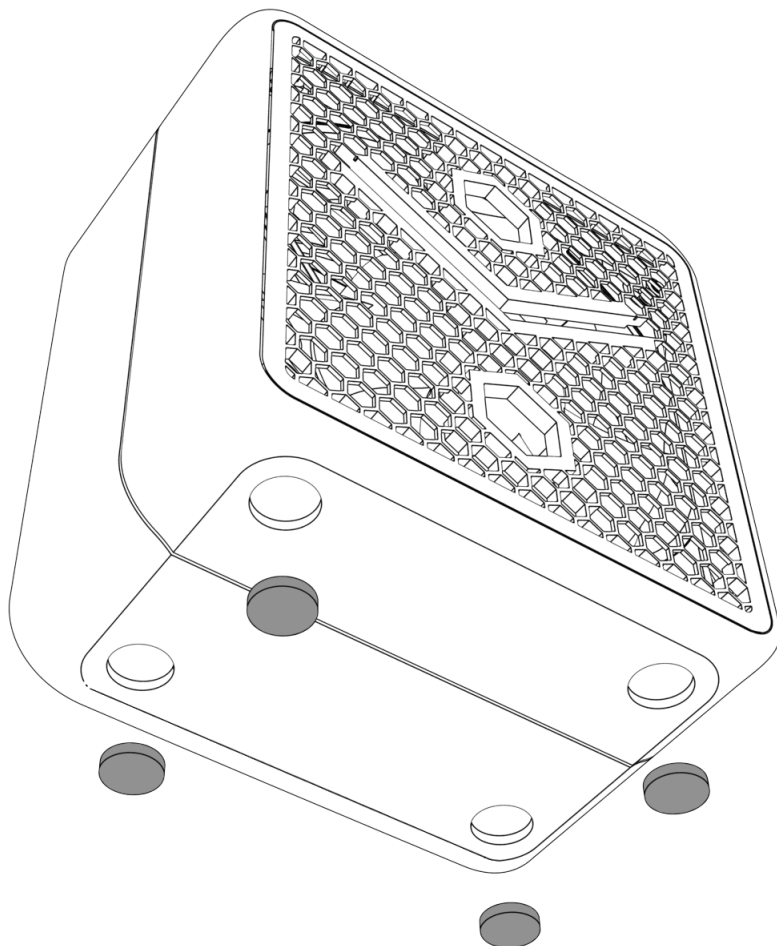

## STEP 12 - LAST ONE

Kit concerned :

- ALVEOONE-R free stand
- ALVEOONE wall mounted

Plug power supply.



Power supply 24V DC jack  
(Provided)



or  
External power supply 24V  
(Double check the polarity)

Slide the electronic board cover in the rails.

The arrows can help you to take the cover out, keep it in a removal direction.

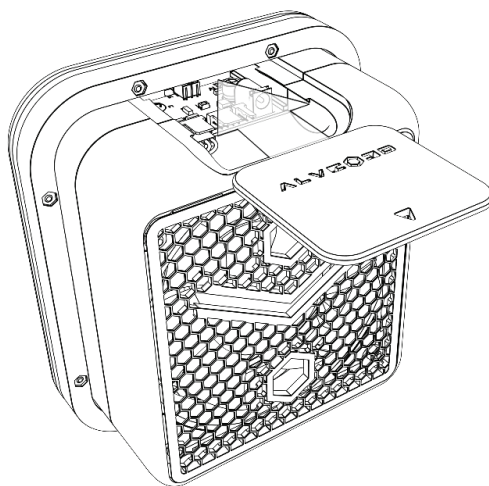

# NOTES

## HEPA Filter P3D lifetime:

Filter working life are associated with many factors including: filament type, melting temperature, concentration of nanoparticles and VOCs, ambient humidity...

We suggest to replace HEPA filter P3D according to the following table:

Filter replacement	Intensive use	Occasional use
	3 months	6 months

We do not recommend going above 600 hours of use before to replace the filter.

## Filter replacement tracking:

	Date
Date of purchase	
Replacement 1	
Replacement 2	
Replacement 3	
Replacement 4	
Replacement 5	
Replacement 6	
Replacement 7	
Replacement 8	
Replacement 9	
Replacement 10	

**Filter replacement tracking:**

	Date
Date of purchase	
Replacement 1	
Replacement 2	
Replacement 3	
Replacement 4	
Replacement 5	
Replacement 6	
Replacement 7	
Replacement 8	
Replacement 9	
Replacement 10	
Replacement 11	
Replacement 12	
Replacement 13	
Replacement 14	
Replacement 15	
Replacement 16	
Replacement 17	
Replacement 18	

**Comments:**

A large rectangular area with a dashed border, intended for writing comments. The area is currently blank.

# Breathe ! You are filtering !

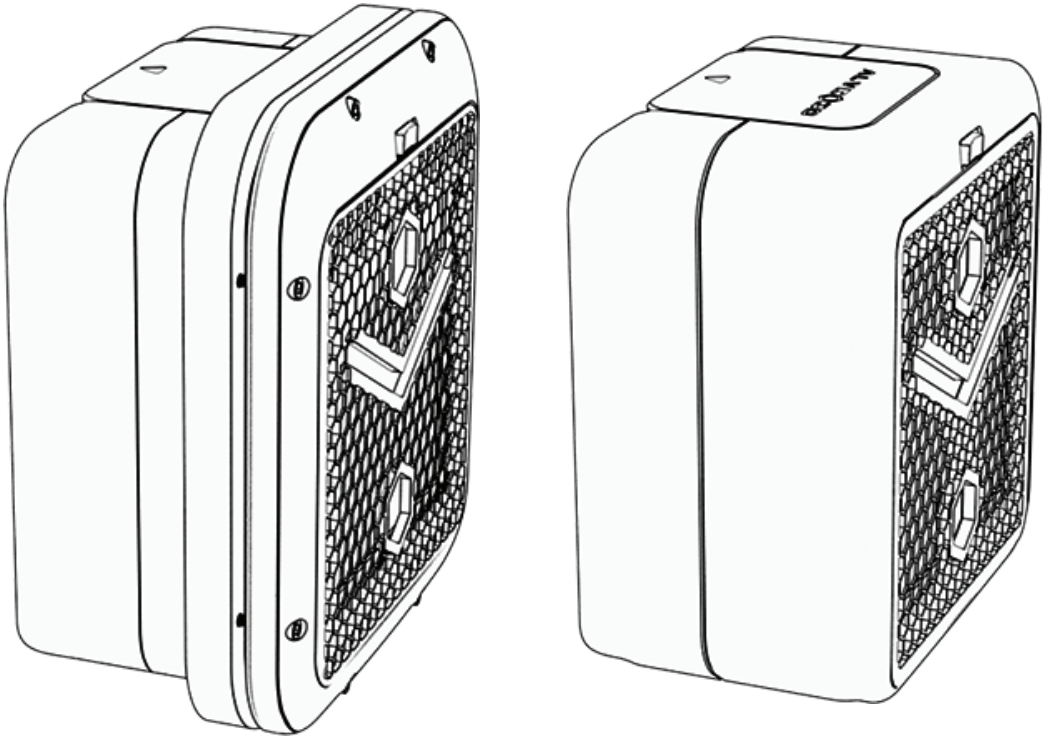

Share your filterbox on [www.facebook.com/alveo3d/](https://www.facebook.com/alveo3d/)

---

ALVEO3D by  
FLEXEE SYSTEM SAS  
386 Rue de la Curiaz  
73290 La Motte-Servolex  
[www.alveo3d.com](http://www.alveo3d.com)  
[contact@alveo3d.com](mailto:contact@alveo3d.com)

**Designed and packaged in France**

---