

Bambu Lab A1 with AMS Lite

Quick Start

Please review the entire guide before operating the printer.

* Safety Notice: Do not connect to power until assembly is complete.

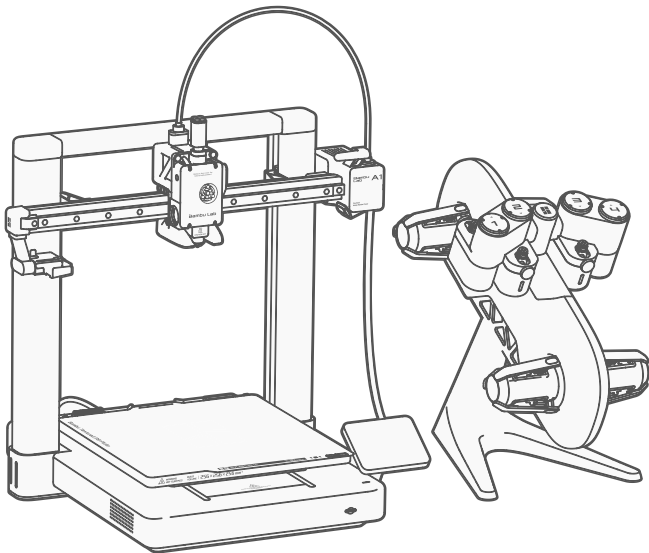

PF002-A

SA005



Bambu Studio & Bambu Handy
<https://bambulab.com/download>

What's In The Box

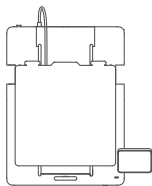

A1 Base Housing

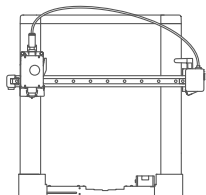

A1 Printer Frame

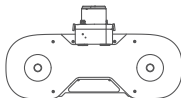

AMS lite Body



AMS lite Stand

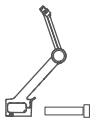

Spool Holder



AMS lite Rotary
Spool Holder
(x4)

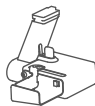

Purge Wiper



Power Cable



PTFE Tubes
For AMS lite



600mm
PTFE Tube



Sample
Filament



Accessory Box



Build Plate

Accessory Box

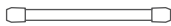

Unclogging Pin Tool



Allen Key H2



Allen Key H1.5



Heated Nozzle Wiper



Cable Organizer



Bambu Scraper Blade



Spare Filament Cutter



Grease & Oil



Supportive Footpad



BT2.6-8 Screw
(For Scraper)
(x2)



BT3-8 Screw
(For AMS Stand)
(x5)



M3-12 Screw
(For Purge Wiper)
(x1)



ST3-23 Screw
(For Base Housing)
(x13)



AMS lite Top Mount
Screws Kit
(For Stiffener / AMS lite)
(For Top Mount Latch / Stiffener C Clamp)

Install Build Plate

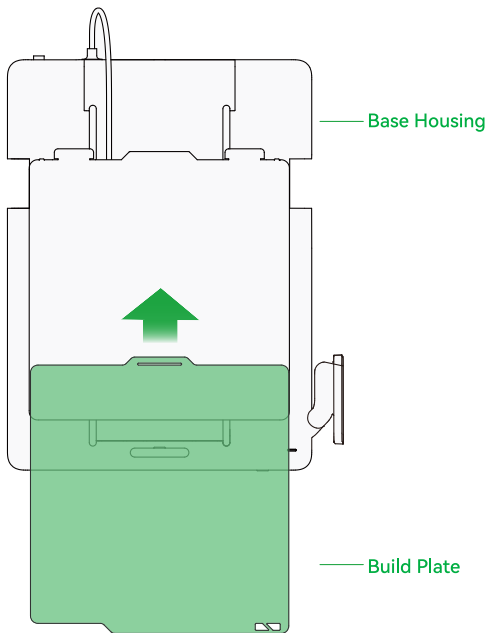

- ① Install the build plate with correct orientation, aligning the edge with the heatbed.

Unlock Heatbed

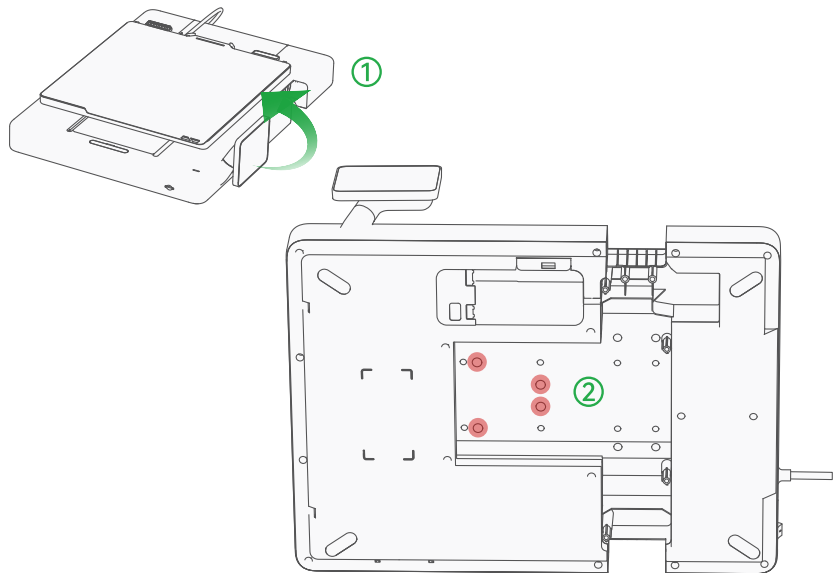

- ① Flip the base housing 90 degree to the side opposite to the screen.
- ② Use Allen Key H2 to remove the 4 highlighted screws at the bottom of the Base Housing to unlock the heatbed.
(Be careful when fully releasing the heatbed; use foam padding in the package to protect the heatbed from swinging.)

Mate Base Housing & Printer Frame

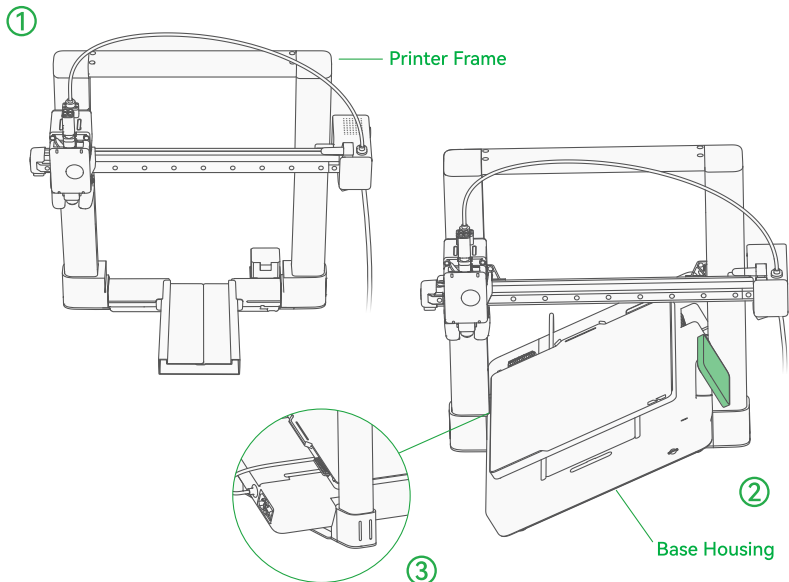

- ① Put the Printer Frame on the table as shown above.
- ② Tilt the Base Housing about 45 degree to pass through the Printer Frame.
(Use the screen as indicator for orientation)
- ③ Align the slot with the Printer Frame as shown in the diagram.
- ④ Slowly lower the Base Housing until it is fully flush with the Printer Frame on the table.

Unlock Toolhead

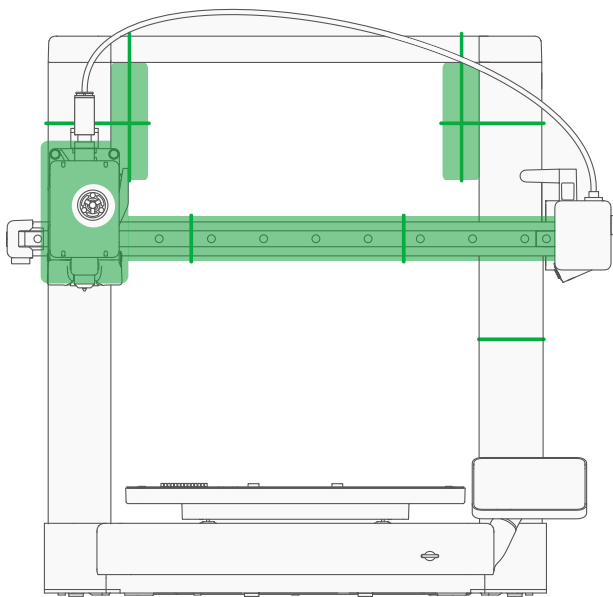

- ① Cut the ziptie and cardboard wrapped around the toolhead and X-axis.
- ② Remove the zipties and foam paddings on the printer frame.

Remove Y-Axis Cover

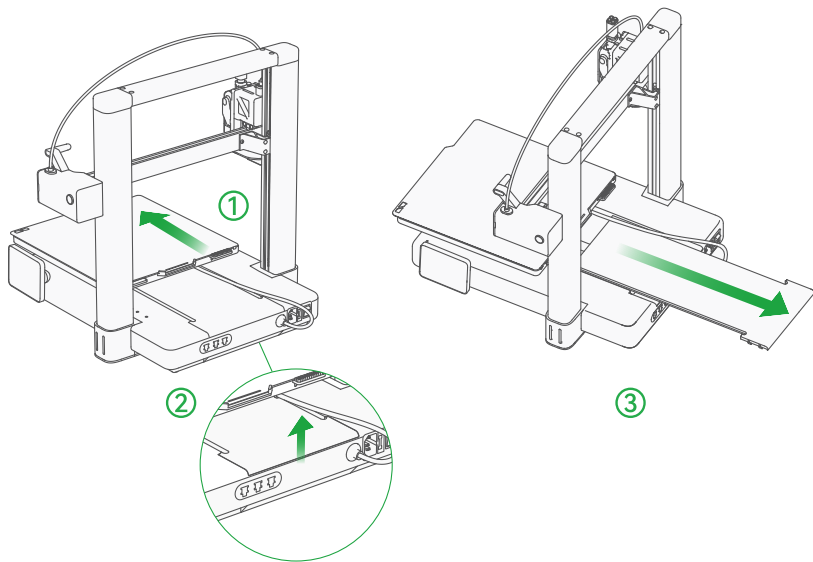

① Push the heatbed fully to the front end, where the screen is located.

② Open the Y-axis cover.

③ Pull out the Y-axis cover gently.

Lock Base Housing

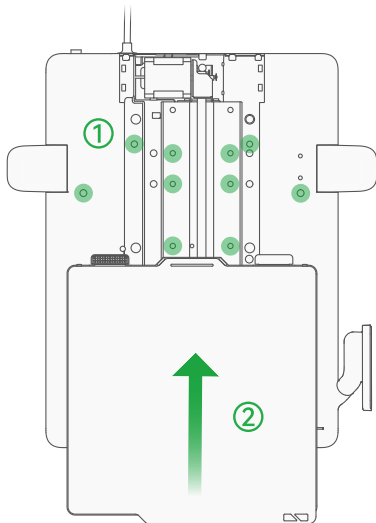

① Install 10*ST3-23 Screws (For Base Housing) in the holes highlighted in green.

② Push the heatbed to the other end.

Lock Base Housing

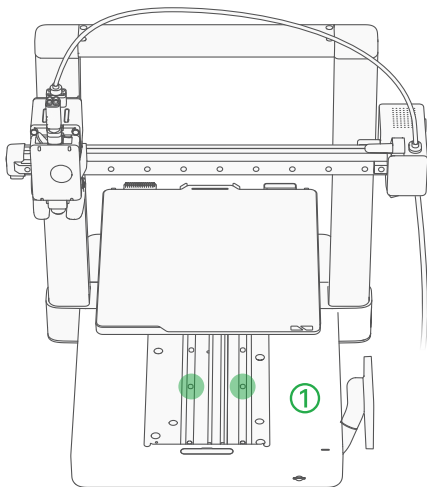

- ① Install 2*ST3-23 Screws (For Base Housing) in the holes highlighted in green.

Put Cover Back

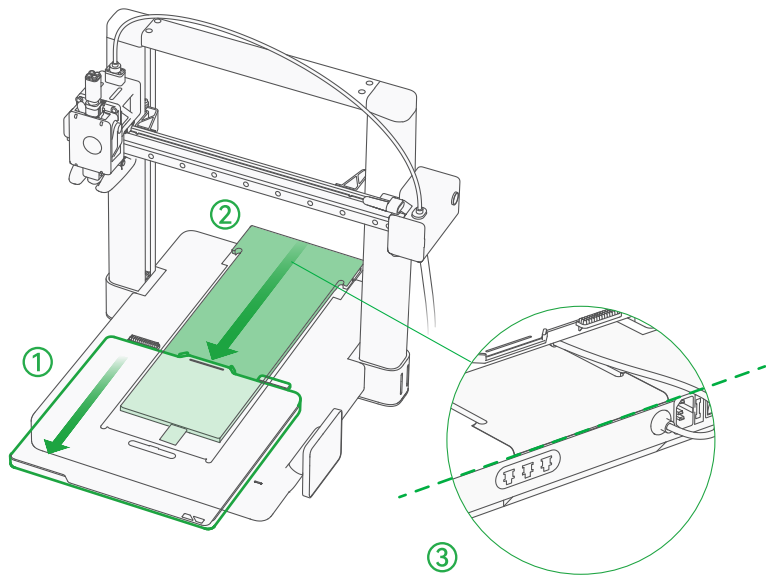

- ① Push the heatbed fully to the front end, where the screen is located.
- ② Gently slide the Y-axis cover back into place.
- ③ Make sure to align the clip.

Place On Table

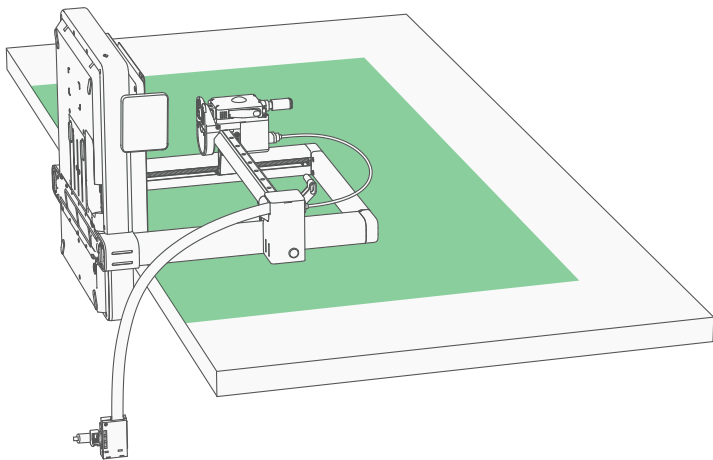

① Turn the A1 90 degree onto its rear, laying it on the edge of a table.

(It is recommended to cover the table with cardboard for protection.)

Please make sure the printer is secure on the table while following the steps.

Plug In Cable Box

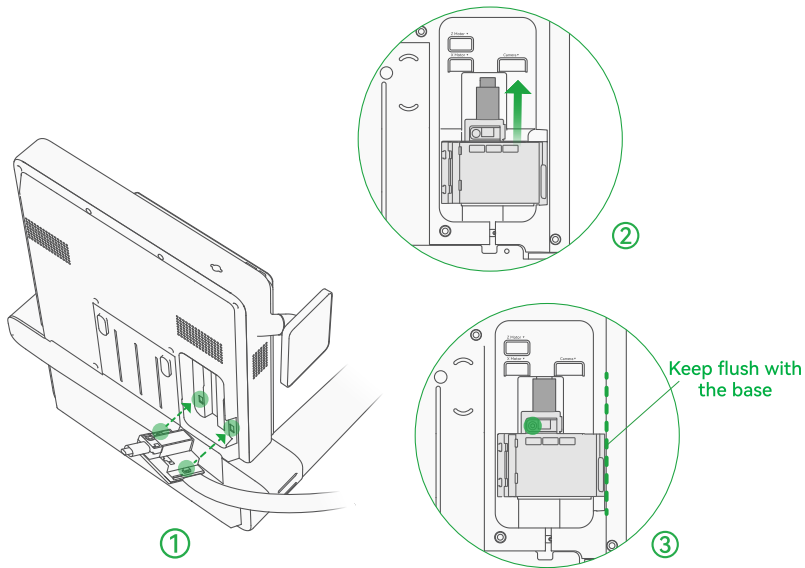

- ① Align the 2 clips on the cable box with the holes on the Base Housing.
- ② Slide up the cable box until the Type-C cable clicks in place. (DO NOT force the insert.)
- ③ Make sure the cable box is nice and flush in the slot, then screw in the pre-installed screw highlighted in green.

Plug In Connectors

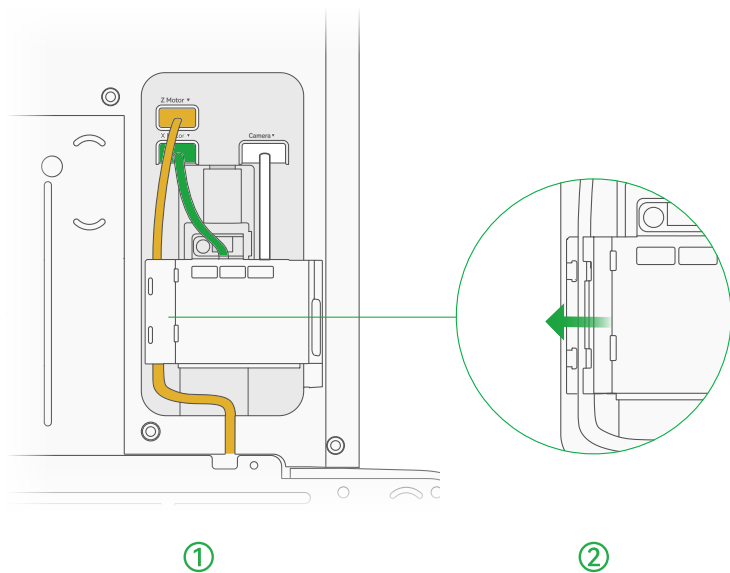

① Plug in the 3 harnesses according to color.

② Tuck the harness into the cable slot and then close the cover.

Fold Out Touch Screen

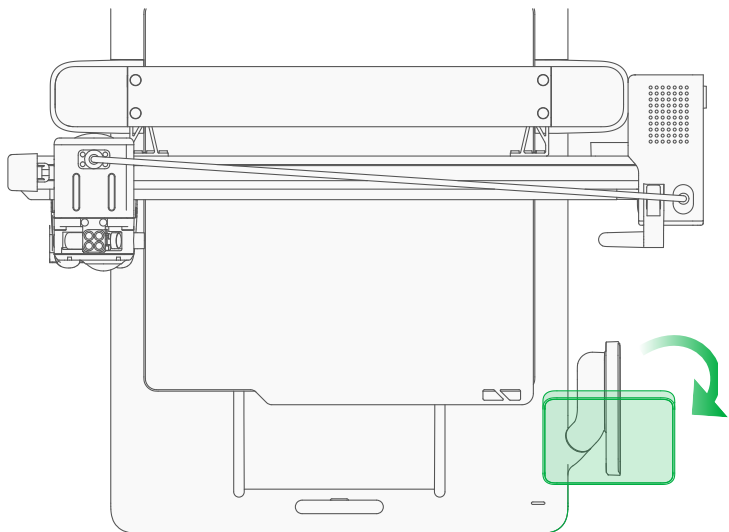

- ① Fold out the touch screen. Make sure the touch screen is in place as shown in the graph.

Install Purge Wiper

Push the toolhead to the middle of the rail, leaving enough space for purge wiper installation.

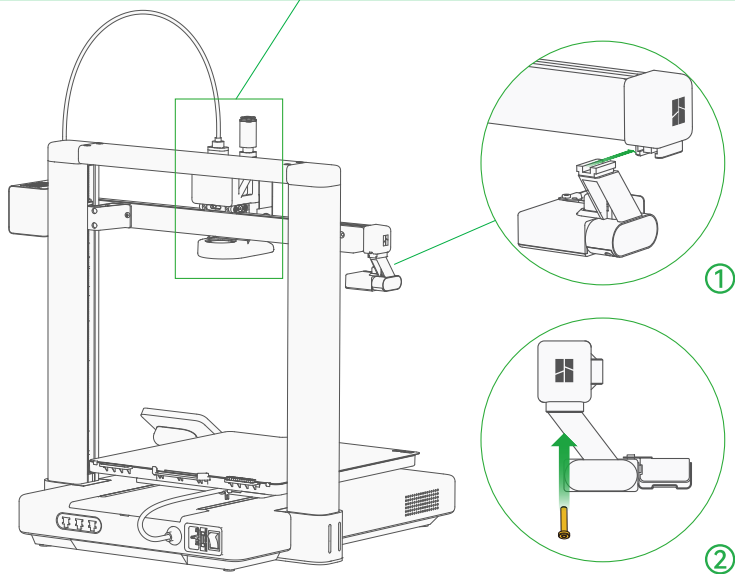

① Slide in Purge Wiper unit into the slot at the end of the X-axis.

② Install the 1*M3-12 screw from the accessory box to fix the Purge Wiper in place.

AMS lite Assembly

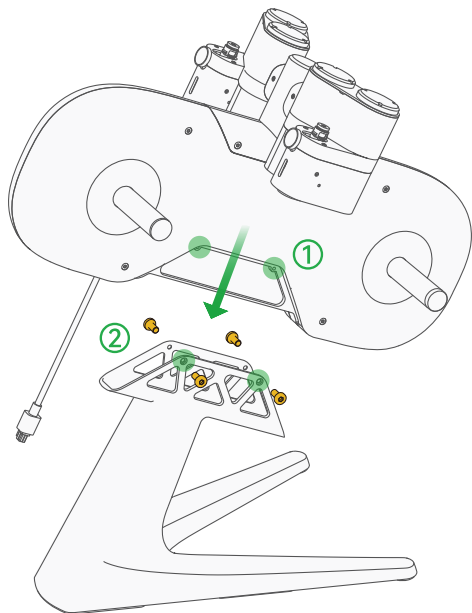

① Put the AMS lite body on the stand (cable on the upward end).

② Secure the AMS lite with the 4*BT3-8 screws (For AMS Stand) from the accessory box.

AMS lite Assembly

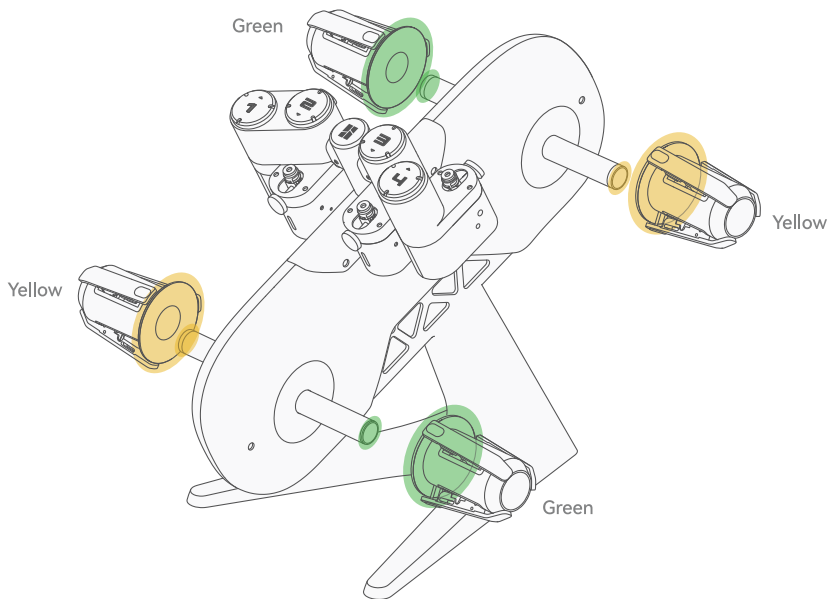

- ① Slide the rotary spool holders on (all the way in), being careful to match colors to avoid damaging any parts.

AMS lite Assembly

Short

Long

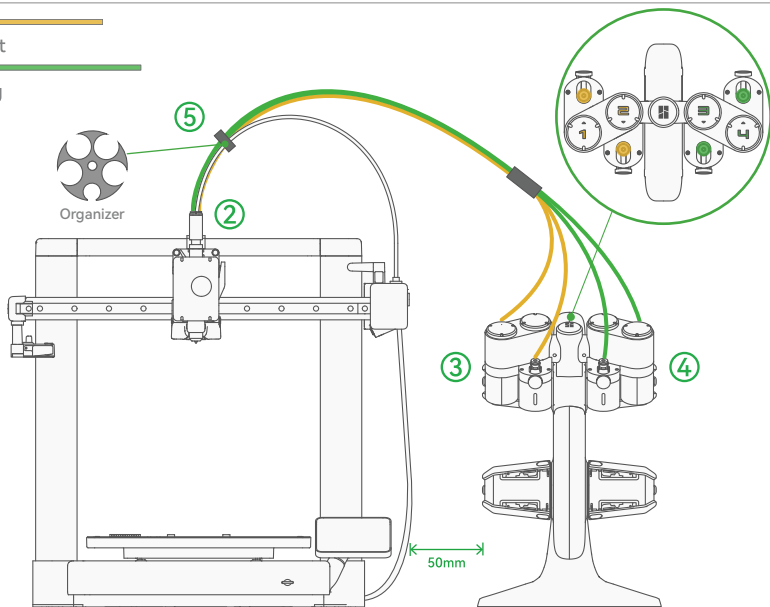

① Put AMS lite to the right side of the A1.

③ Insert short PTFE tubes into ports 1 and 2.

⑤ Clip the black data cable into the organizer.

② Insert all four PTFE tubes into the toolhead filament hub.

④ Insert long PTFE tubes into ports 3 and 4.

(The recommended distance between A1 and AMS lite is 50mm as shown in the diagram.)

Powering On

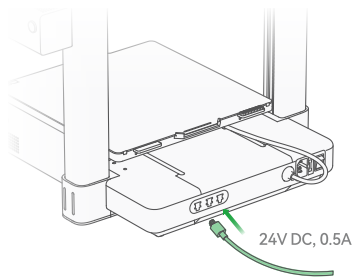

- ① Plug the AMS lite 4pin connector into the port on the back of the A1 (either one).

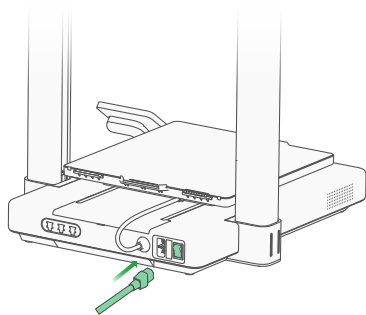

- ② Plug in the power cable and turn on the A1 using the power switch on the back.

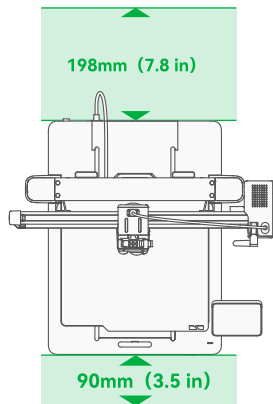

Please leave a safety margin:
198mm at the back and 90mm at the front.

Network Setting



- ① Follow the instructions until you see this screen. Press “Select Wi-Fi” to search for available network.

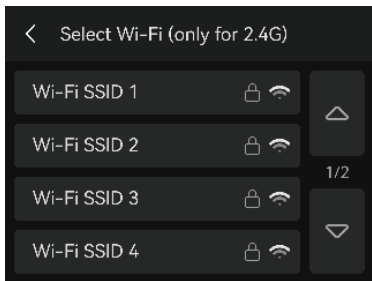

- ② Select your preferred network.



- ③ Input the passcode, and then press “OK”.

Printer Binding

- 1 Download the Bambu Handy App. Register and log in to your Bambu Lab account.
- 2 Use Bambu Handy to scan the QR code on the screen, and bind your printer to your Bambu Lab account.
- 3 Follow the instructions on the screen to complete the initial calibration. It is normal to have vibration and noise during the calibration process.

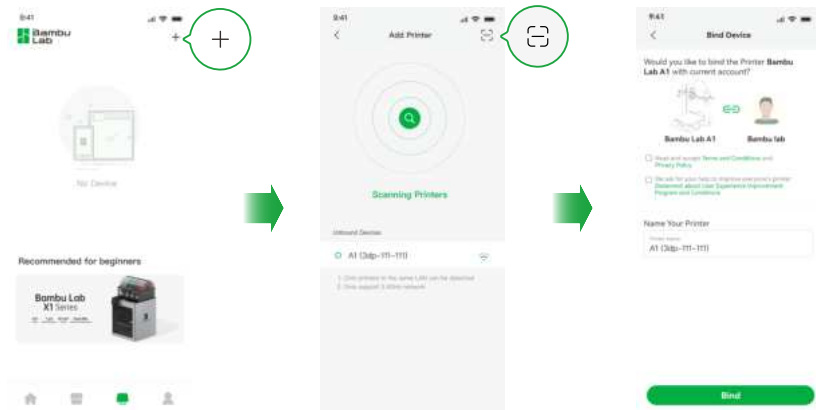
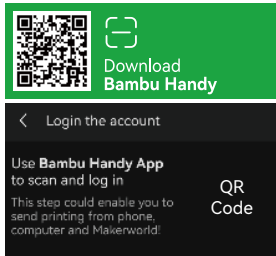

Spool Loading

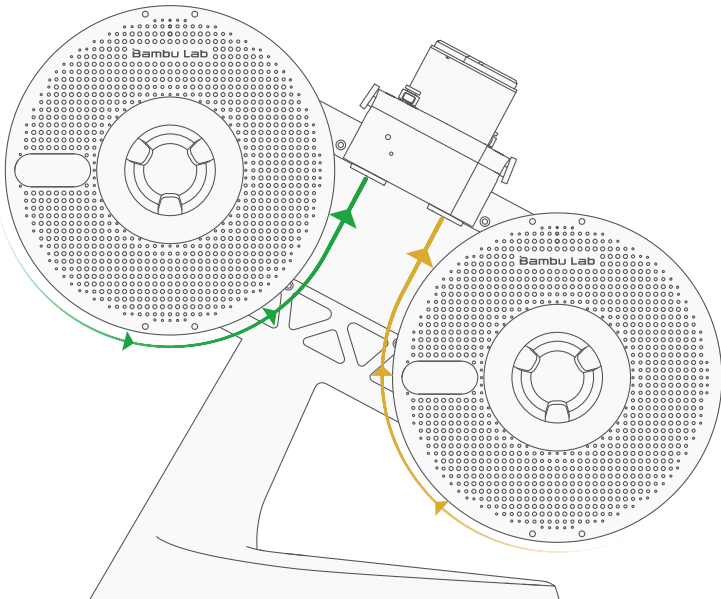

- ① Orient spool installation according to the filament winding direction (as shown in the diagram).

*Warning

- ① The AMS lite supports spools with a width of 40–68 mm and an inner diameter of 53–58 mm.
- ② Avoid using AMS lite to print flexible materials, including TPU, TPE, or absorbent PVA. Avoid using materials that are too hard (too high modulus) or too brittle (not enough toughness), including third-party fiber reinforcement materials (PA-CF/GF, PET-CF/GF, PLA-CF/GF, etc.). Please use external spool placement to print these filament.

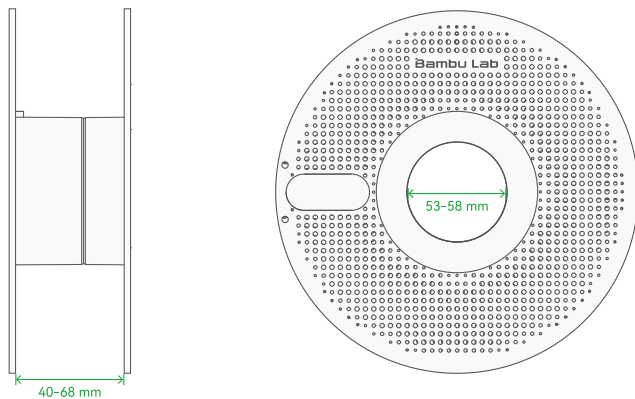

Spool Loading

Note: Press the release button to disengage drive motor if filament stuck.

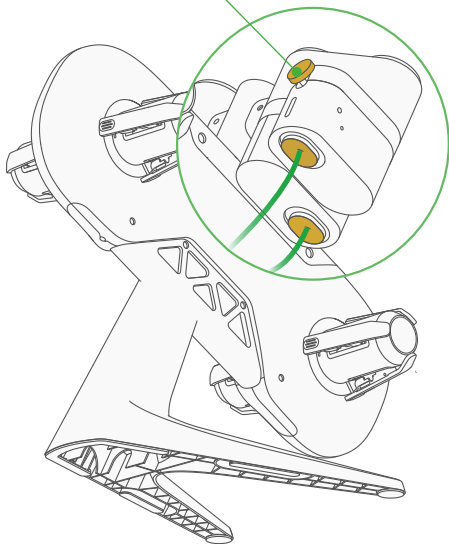
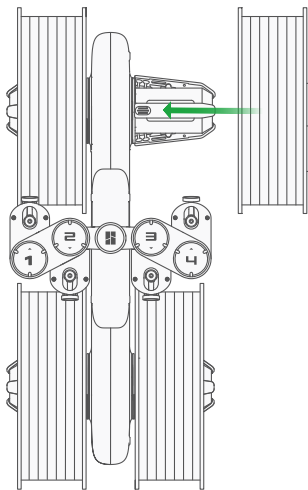

① Push the spool all the way onto the spool retractor. Make sure it fully click into place.

② Feed the filament into the filament inlet.

External Spool (for non-AMS use case)

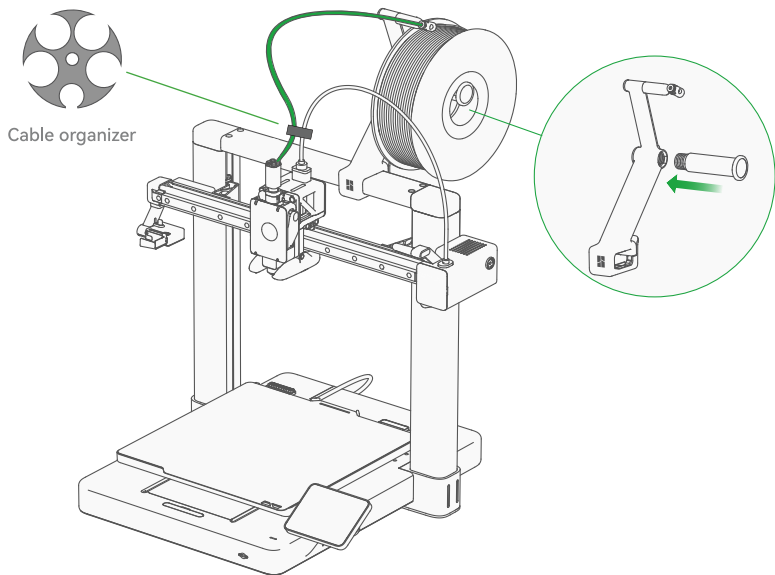

- ① Assemble the spool holder.
- ② Connect the toolhead filament inlet (either one of four) and the filament guide with the 600mm PTFE tube as shown in the diagram.
- ③ Install the cable organizer as shown in the graph.
- ④ Hang filament spool on spool holder then feed the filament line into the PTFE tube as shown in the diagram.

First Print

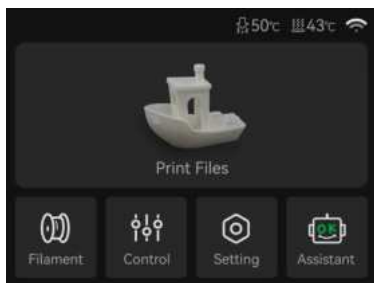

- ① Press “Print Files” to access the preloaded models on the SD card.



- ② Select the model you want to print.



- ③ Turn on “Use AMS” if you are using filaments on AMS.

Turning on “Bed leveling” is recommended.

Turn on “Timelapse” for timelapse video recording.

AMS Mapping

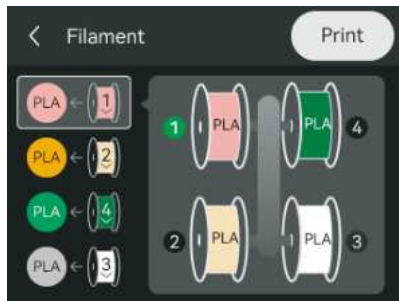

Map the actual filaments you have to the print file preset filaments.

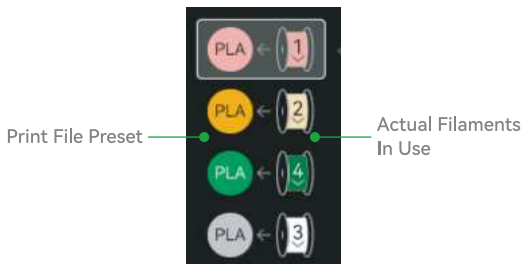

Note: We recommend using similar colors to match the preset. Otherwise the flush setting might be inaccurate.

Specification

Item		Specification
Printing Technology		Fused Deposition Modeling
Body	Build Volume (W×D×H)	256*256*256 mm ³
	Chassis	Steel + Extruded Aluminum
Toolhead	Hot End	All-Metal
	Extruder Gears	Steel
	Nozzle	Stainless Steel
	Max Hot End Temperature	300 °C
	Nozzle Diameter (Included)	0.4 mm
	Nozzle Diameter (Optional)	0.2 mm, 0.6 mm, 0.8 mm
	Filament Cutter	Yes
	Filament Diameter	1.75 mm
Heatbed	Compatible Build Plate	Bambu Textured PEI Plate Bambu Smooth PEI Plate Bambu Cool Plate
	Max Build Plate Temperature	100 °C
Speed	Max Speed of Tool Head	500 mm/s
	Max Acceleration of Tool Head	10000 mm/s ²
	Max Hot End Flow	28 mm ³ /s @ABS (Model: 150*150 mm single wall; Material: Bambu ABS; Temperature: 280 °C)
Cooling	Part Cooling Fan	Closed Loop Control
	Hot End Fan	Closed Loop Control
Supported Filament	PLA, PETG, TPU, PVA	Ideal
	ABS, ASA, PC, PA, PET, Carbon/Glass Fiber Reinforced Polymer	Not Recommended
Sensors	Monitoring Camera	Low Rate Camera (up to1080P) Timelapse Supported
	Filament Run Out Sensor	Yes
	Filament Odometry	Yes
	Power Loss Recover	Yes
	Filament Tangle Sensor	Yes
Physical Dimensions	Dimensions (W×D×H)	465*410*430 mm ³
	Net Weight	8.3 kg

Specification

Electrical Parameters	Input Voltage	100-240 VAC, 50/60 Hz
	Max Power	1300W@220V, 350W@110V
Electronics	Display	3.5 inches 320*240 IPS Touch Screen
	Connectivity	Wi-Fi, Bambu-Bus
	Storage	Micro SD Card
	Control Interface	Touch Screen, APP, PC Application
	Motion Controller	Dual-Core Cortex M4
Software	Slicer	Bambu Studio Support third party slicers which export standard Gcode such as Superslicer, Prusaslicer and Cura, but certain advanced features may not be supported.
	Slicer Supported OS	MacOS, Windows
Wi-Fi	Frequency Range	2412 MHz - 2472 MHz (CE) 2412 MHz - 2462 MHz (FCC) 2400 MHz - 2483.5 MHz (SRRC)
	Transmitter Power (EIRP)	≤ 21.5 dBm (FCC) ≤ 20 dBm (CE/SRRC)
	Protocol	IEEE 802.11 b/g/n



Bambu Studio
Bambu Handy

<https://bambulab.com/download>



Bambu Lab

Enjoy!

www.bambulab.com