

Bambu Lab A1 mini with AMS Lite

Quick Start

Please review the entire guide before operating the printer.

* Safety Notice: Do not connect to power until assembly is complete.

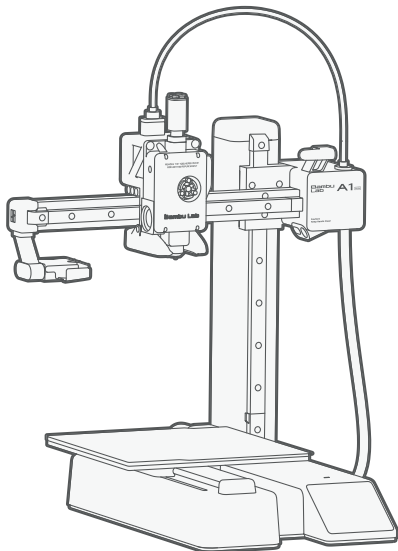

PF002-M

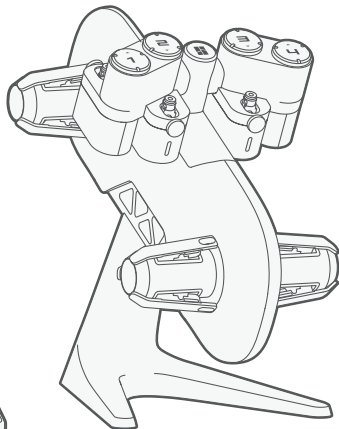

SA005



Bambu Studio & Bambu Handy
<https://bambulab.com/download>

What's In The Box

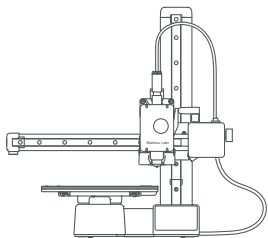

A1 mini

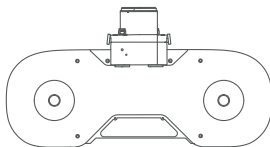

AMS lite Body

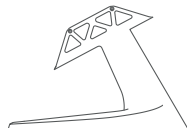

AMS lite Stand



Spool Holder



Accessory Box



AMS lite Rotary
Spool Holder
(x4)



Purge Wiper



Quick Start



580mm
PTFE Tube (x2)



700mm
PTFE Tube (x2)



Sample
Filament



Build Plate

Accessory Box



Unlogging Pin Tool



Allen Key H2



Allen Key H1.5



Cable Organizer



Bambu
Scraper Blade



Spool Holder Base



Grease & Oil



BT2.6-8 Screw (x2)
(For Scraper)



BT3-8 Screw (x5)
(For AMS Stand)



M3-8 Screw (x2)
(For Spool Holder)



M3-12 Screw (x1)
(For Purge Wiper)

Unlock

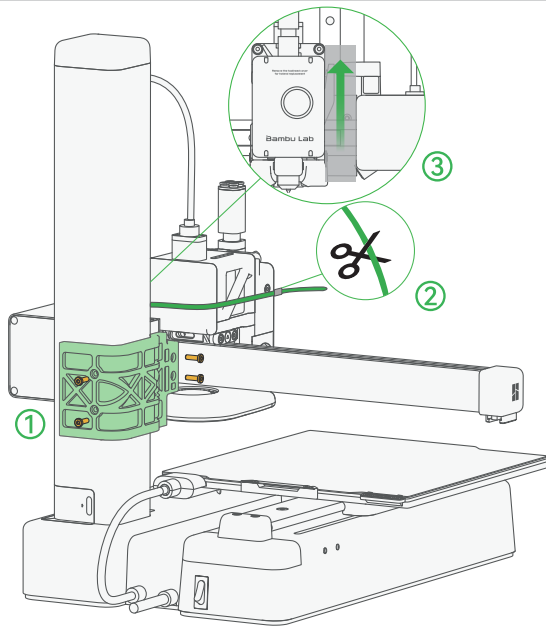

- ① Remove the 4 screws to unlock the Z-axis limiter.
- ② Cut the ziptie wrapped around the toolhead.
- ③ Remove the foam padding.

Lock Heatbed

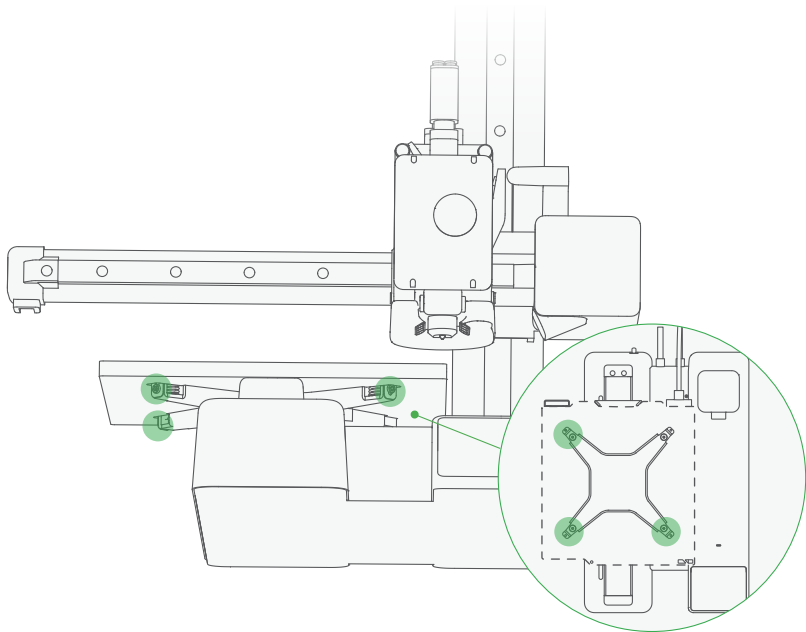

① Tighten the 3 screws circled in green to lock the heatbed.

Purge Wiper Installation

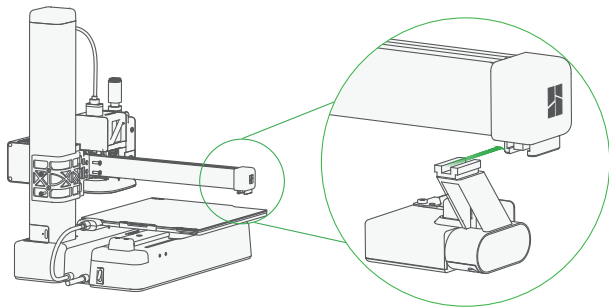

- ① Slide in the Purge Wiper unit into the slot at the end of the X-Axis.

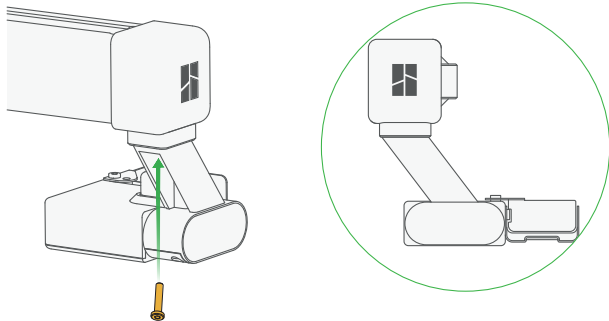

- ② Install the 1*M3-12 screw (For Purge Wiper) from the accessory box to fix the Purge Wiper in place.

Spool Holder Installation

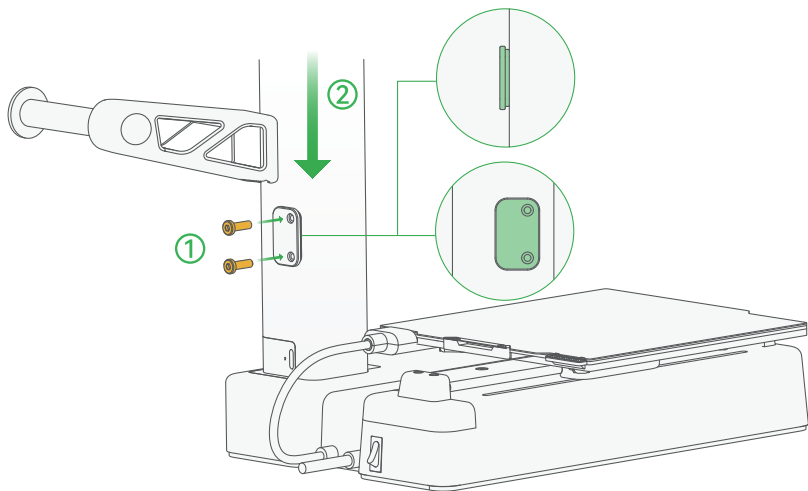

- ① Install the spool holder base plate with the 2*M3-8 screws (For Spool Holder) from the accessory box.
- ② Slide in the spool holder (match the slot orientation).

AMS lite Assembly

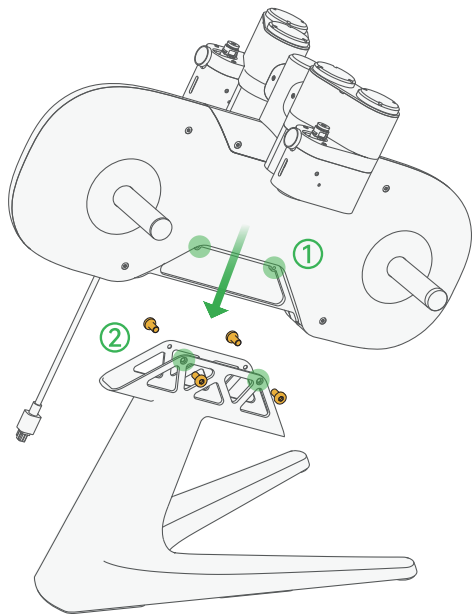

- ① Put the AMS lite body on the stand (cable on the upward end).
- ② Secure the AMS lite with the 4*BT3-8 screws (For AMS Stand) from the accessory box.

AMS lite Assembly

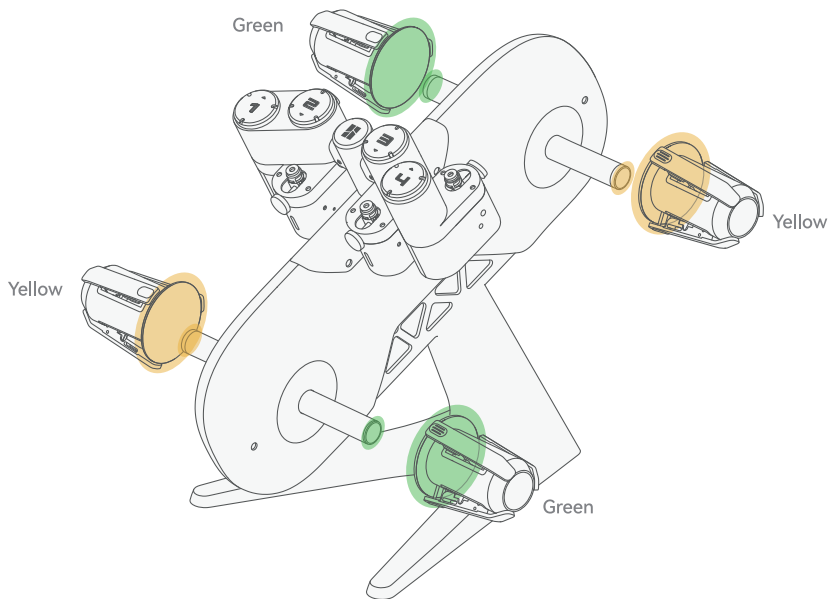

- ① Slide the rotary spool holders on (all the way in), being careful to match colors to avoid damaging any parts.

AMS lite Assembly

580mm (short)

700mm (long)

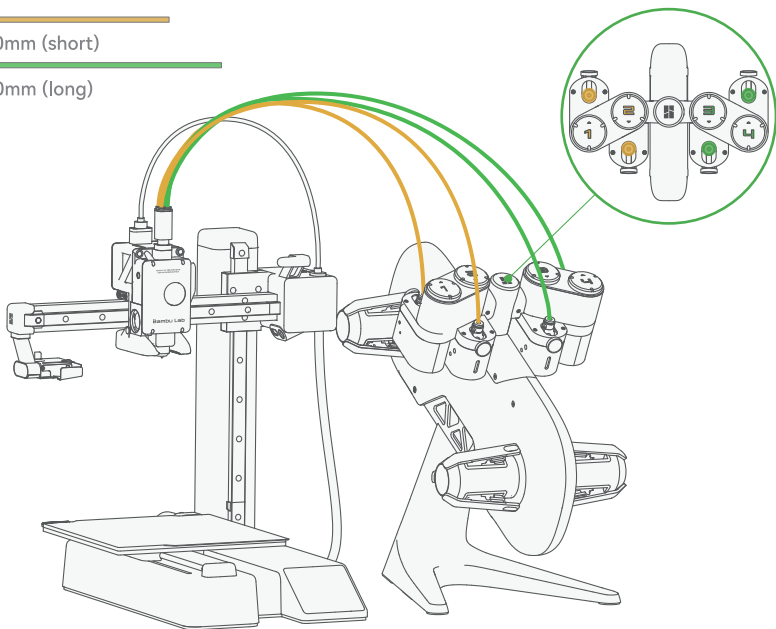

- ① Put AMS lite to the right side of the A1 mini.
- ② Insert 700mm PTFE tubes into ports 3 and 4.
- ③ Insert 580mm PTFE tubes into ports 1 and 2.
- ④ Insert all four PTFE tubes into the toolhead filament hub.

Organizer Installation

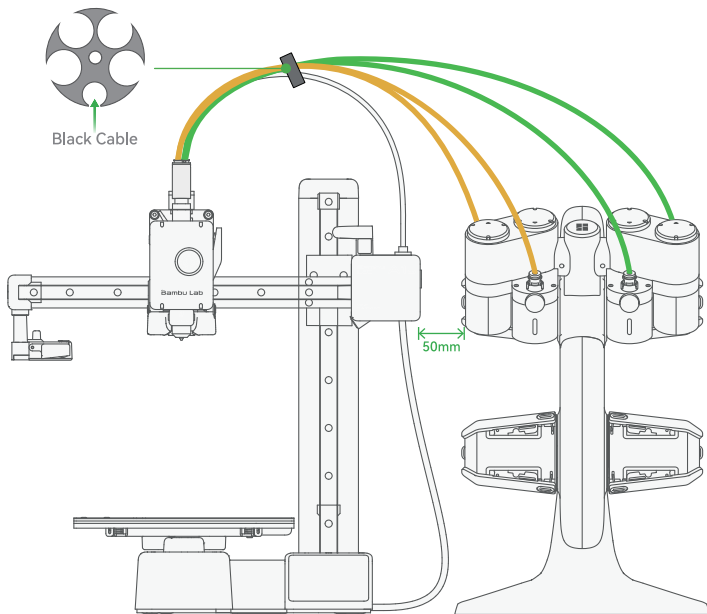

- ① Install the organizer as shown in the diagram.
- ② Clip the black cable into the smaller hole.
- ③ The other four holes are for PTFE tubes.

(Recommend distance between A1 mini and AMS lite is 50mm as shown in the diagram.)

Powering On

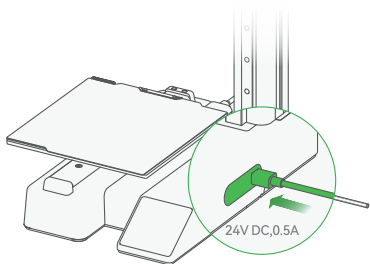

① Plug the AMS lite 4-pin connector into either one of the ports on the right side of the A1 mini.

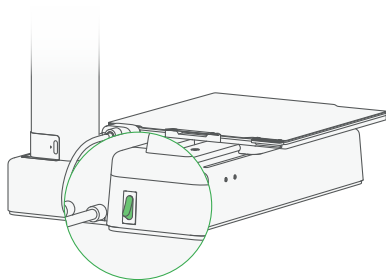

② Turn on the A1 mini using the power switch on the back.

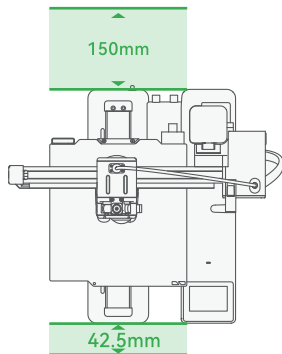

Please leave a safety margin:
150mm at the back and 42.5mm at the front.

Network Setting

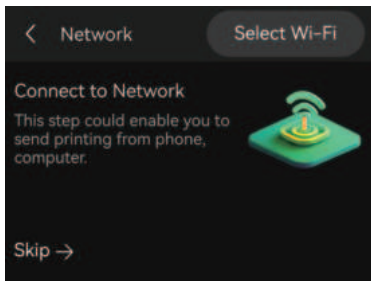

- ① Follow the instructions until you see this screen. Press “Select Wi-Fi” to search for available network.

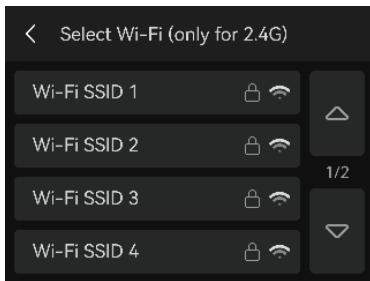

- ② Select your preferred network.

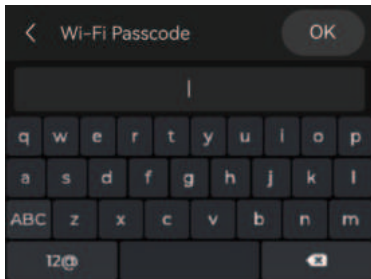

- ③ Input the passcode, and then press “OK”.

Printer Binding

- ① Download the Bambu Handy App. Register and log in to your Bambu Lab account.
- ② Use Bambu Handy to scan the QR code on the screen, and bind your printer to your Bambu Lab account.
- ③ Follow the instructions on the screen to complete the initial calibration. It is normal to have vibration and noise during the calibration process.

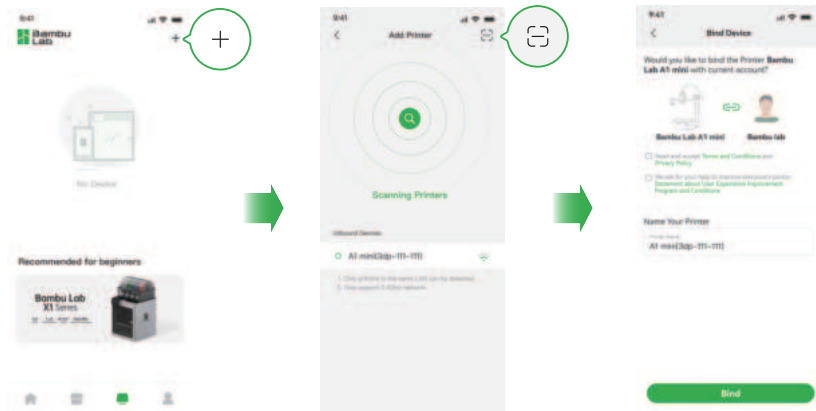
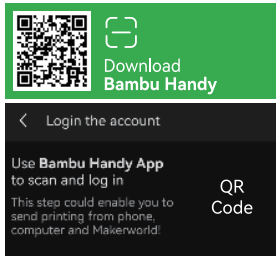

Spool Loading

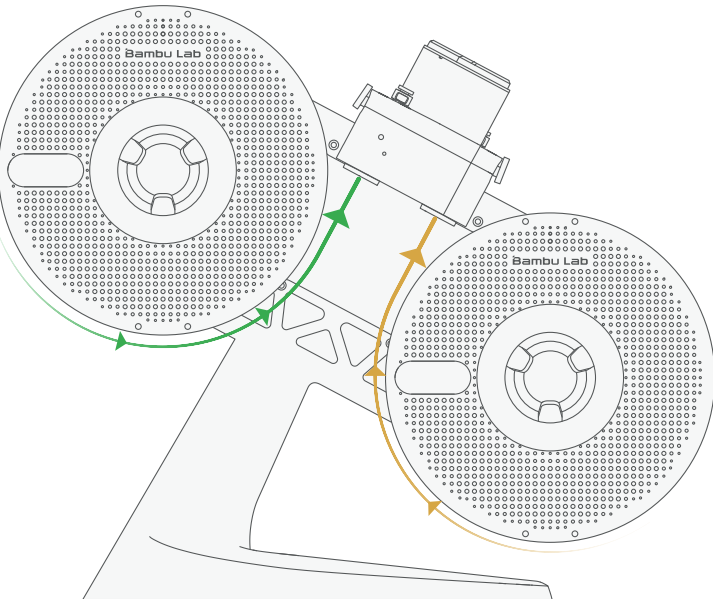

- ① Orient spool installation according to the filament winding direction on (as shown in the diagram).

*Warning

- ① The AMS lite supports spools with a width of 40-68 mm and an inner diameter of 53-58 mm.
- ② Avoid using AMS lite to print flexible materials, including TPU, TPE, or absorbent PVA. Avoid using materials that are too hard (too high modulus) or too brittle (not enough toughness), including third-party fiber reinforcement materials (PA-CF/GF, PET-CF/GF, PLA-CF/GF, etc.). Please use external spool placement to print these filament.

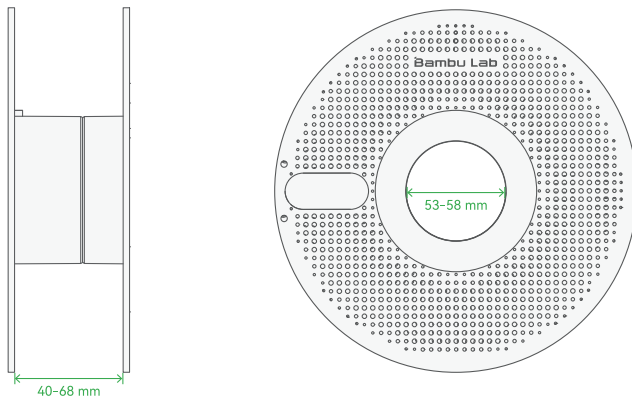

Spool Loading

Note: Press the release button to disengage drive motor if filament stuck.

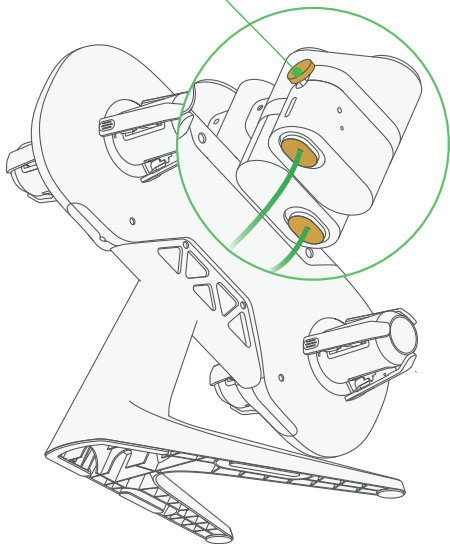
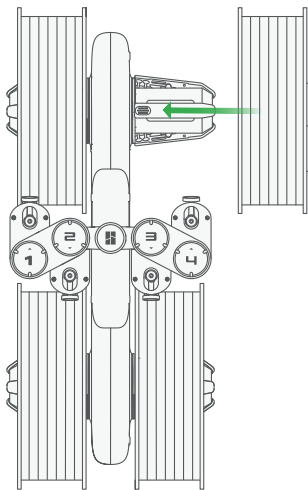

① Push the spool all the way onto the spool retractor. Make sure it fully click into place.

② Feed the filament into the filament inlet.

External Spool (for non-AMS use case)

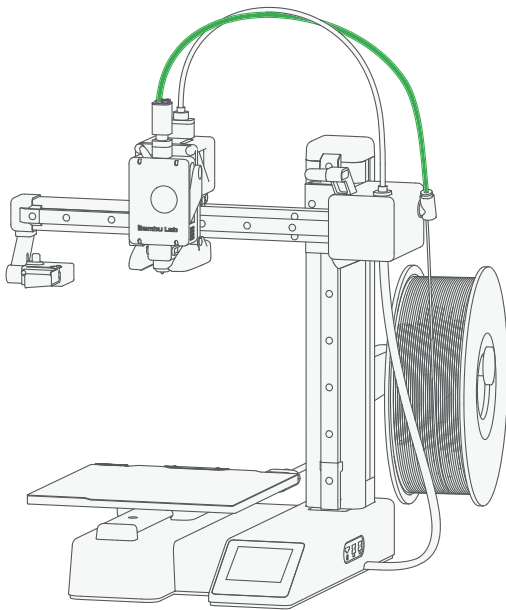

- ① Connect the toolhead filament inlet (either one of four) and the filament guide with the PTFE tube as shown in the diagram.
- ② Hang filament spool on spool holder then feed the filament line into the PTFE tube as shown in the diagram.

First Print

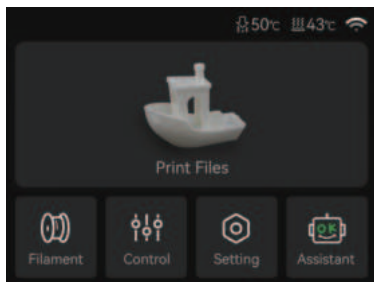

- ① Press “Print Files” to access the preloaded models on the SD card.



- ② Select the model you want to print.



- ③ Turn on “Use AMS” if you are using filaments on AMS.

Turning on “Bed leveling” is recommended.

Turn on “Timelapse” for timelapse video recording.

AMS Mapping

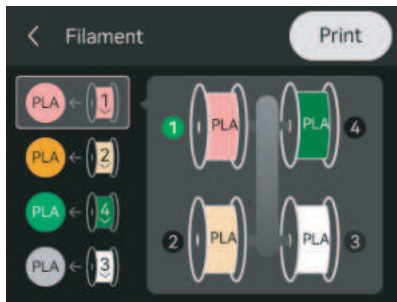

Map the actual filaments you have to the print file preset filaments.

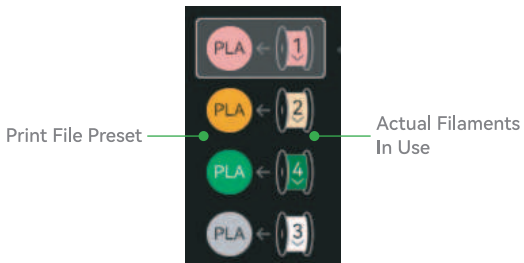

Note: We recommend using similar colors to match the preset. Otherwise the flush setting might be inaccurate.

Specification

Item		Specification
Printing Technology		Fused Deposition Modeling
Body	Build Volume (W×D×H)	180*180*180 mm ³
	Chassis	Steel + Extruded Aluminum
Toolhead	Hot End	All-Metal
	Extruder Gears	Steel
	Nozzle	Stainless Steel
	Max Hot End Temperature	300 °C
	Nozzle Diameter (Included)	0.4 mm
	Nozzle Diameter (Optional)	0.2 mm, 0.6 mm, 0.8 mm
	Filament Cutter	Yes
	Filament Diameter	1.75 mm
Heatbed	Compatible Build Plate	Bambu Textured PEI Plate Bambu Smooth PEI Plate
	Max Build Plate Temperature	80 °C
Speed	Max Speed of Tool Head	500 mm/s
	Max Acceleration of Tool Head	10000 mm/s ²
	Max Hot End Flow	28 mm ³ /s @ABS (Model: 150*150 mm single wall; Material: Bambu ABS; Temperature: 280 °C)
Cooling	Part Cooling Fan	Closed Loop Control
	Hot End Fan	Closed Loop Control
	MC Board Cooling Fan	Closed Loop Control
Supported Filament	PLA, PETG, TPU, PVA	Ideal
	ABS, ASA, PC, PA, PET, Carbon/Glass Fiber Reinforced Polymer	Not Recommended
Sensors	Monitoring Camera	Low Rate Camera (up to 1080P) Timelapse Supported
	Filament Run Out Sensor	Yes
	Filament Odometry	Yes
	Power Loss Recover	Yes
	Filament Tangle Sensor	Yes
Physical Dimensions	Dimensions (W×D×H)	347*315*365 mm ³
	Net Weight	5.5 kg

Specification

Electrical Parameters	Input Voltage	100-240 VAC, 50/60 Hz
	Max Power	150 W
Electronics	Display	2.4 inches 320*240 IPS Touch Screen
	Connectivity	Wi-Fi, Bambu-Bus
	Storage	Micro SD Card
	Control Interface	Touch Screen, APP, PC Application
	Motion Controller	Dual-Core Cortex M4
Software	Slicer	Bambu Studio Support third party slicers which export standard Gcode such as SuperSlicer, PrusaSlicer and Cura, but certain advanced features may not be supported.
	Slicer Supported OS	MacOS, Windows
Wi-Fi	Frequency Range	2412 MHz - 2472 MHz (CE) 2412 MHz - 2462 MHz (FCC) 2400 MHz - 2483.5 MHz (SRRC)
	Transmitter Power (EIRP)	≤ 21.5 dBm (FCC) ≤ 20 dBm (CE/SRRC)
	Protocol	IEEE 802.11 b/g/n



Bambu Studio
Bambu Handy

<https://bambulab.com/download>

