

TECHNICAL DATA SHEET

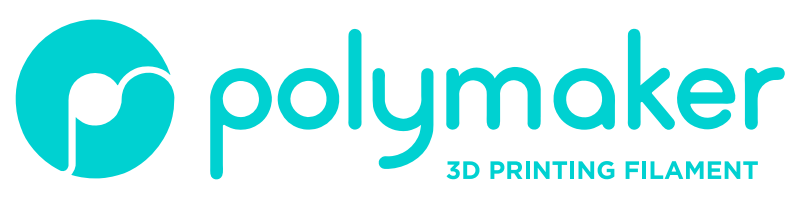

V6.0



Polymaker™ ABS

Polymaker™ ABS is made with a specialty bulk-polymerized ABS resin, which has significantly lower volatile content compared to traditional ABS resins. It delivers excellent printing quality with minimal odor during printing.

WWW.POLYMAKER.COM

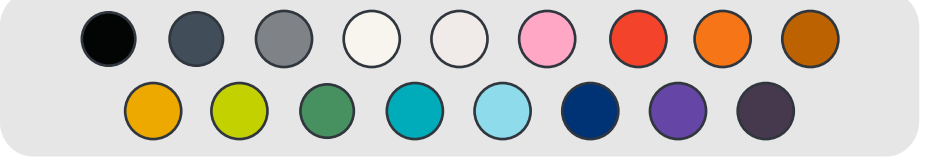

PHYSICAL PROPERTIES

PROPERTY	TESTING METHOD	TYPICAL VALUE
Density	ISO1183, GB/T1033	1.04 g/cm ³ at 23°C
Melt index	220°C, 2.16kg	9-14g /10min
Light transmission	N/A	N/A
Light transmission	N/A	N/A

MOISTURE ABSORPTION CURVE

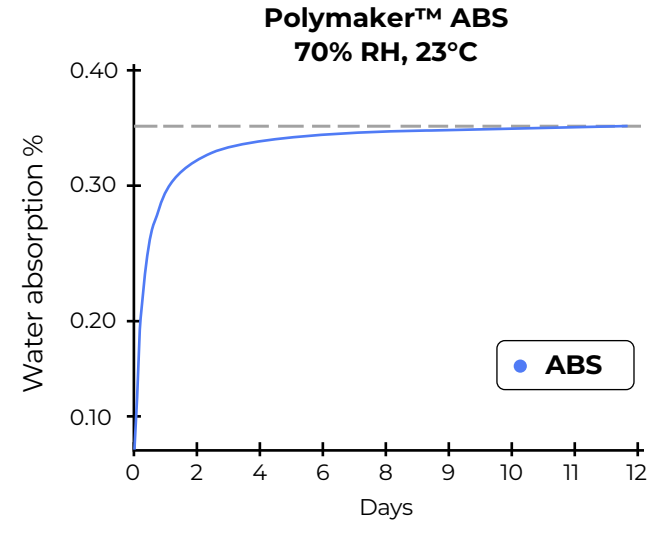

THERMAL PROPERTIES

PROPERTY	TESTING METHOD	TYPICAL VALUE
Glass transition temp.	DSC, 10°C/min	101°C
Melting temp.	DSC, 10°C/min	N/A
Crystallization temp.	DSC, 10°C/min	N/A
Decomposition temp.	TGA, 20°C/min	>380°C
Vicat softening temp.	ISO 306, GB/T 1633	104°C
Heat deflection temp.	ISO 75 1.8MPa	98°C
Heat deflection temp.	ISO 75 0.45MPa	100°C

HDT CURVE

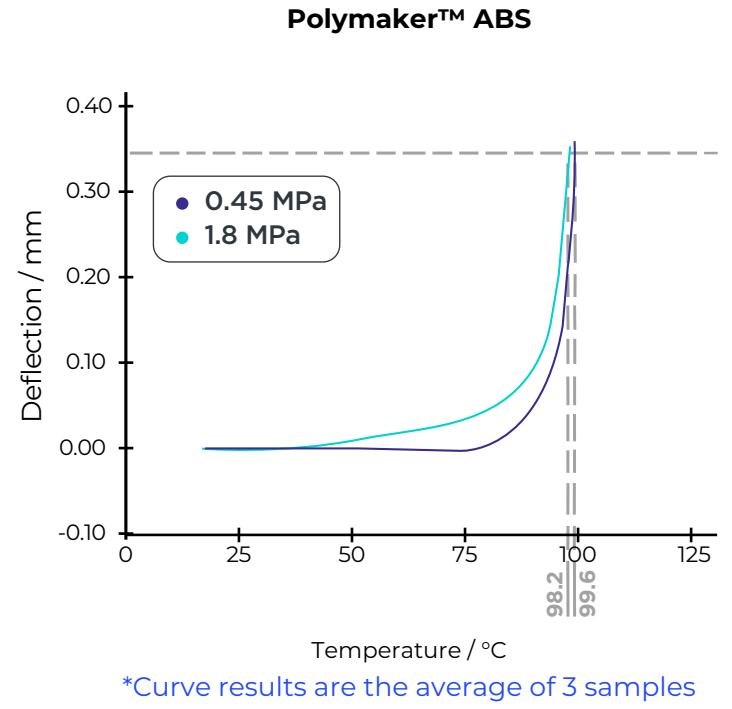

MECHANICAL PROPERTIES

PROPERTY	TESTING METHOD	TYPICAL VALUE
Young's modulus (X-Y)	ISO 527, GB/T 1040	2246.6 ± 58.2 MPa
Young's modulus (Z)		2080.9 ± 92.7 MPa
Tensile strength (X-Y)	ISO 527, GB/T 1040	33.4 ± 0.6 MPa
Tensile strength (Z)		29.7 ± 0.3 MPa
Elongation at break (X-Y)	ISO 527, GB/T 1040	17.9 ± 1.3%
Elongation at break (Z)		3.1 ± 0.3%
Bending modulus (X-Y)	ISO 178, GB/T 9341	2127.2 ± 29.9 MPa
Bending modulus (Z)		N/A
Bending strength (X-Y)	ISO 178, GB/T 9341	56.2 ± 0.3 MPa
Bending strength (Z)		N/A
Notched Charpy impact strength (X-Y)	ISO 179, GB/T 1043	18.0 ± 0.9 kJ/m ²

CHEMICAL RESISTANCE DATA

PROPERTY	TYPICAL VALUE
Effect of weak acids	Good
Effect of strong acids	Poor
Effect of weak alkalis	Good
Effect of strong alkalis	Fair
Effect of oils and grease	Good

Good:
Material may get minor attack after long periods of storage with chemical at ambient temperature

Fair:
Material can be used for short time contact with chemicals at ambient temperature

Poor:
Material becomes unstable on contact with chemical at ambient temperature

RECOMMENDED PRINTING CONDITIONS

Nozzle temperature	245-265°C
Build plate temperature	90-100°C
Build surface treatment	PC and Textured PEI
Cooling fan	OFF
Closure chamber	Needed

Printing Speed	50-200mm/s
Drying temp. and time	70°C/6H
Retraction distance	1-3 (mm)
Retraction Speed	20-40 (mm/s)

*Based on 0.4mm nozzle. Printing conditions may vary with different nozzle diameters.



PolyBox™ or PolyDryer™ Box
Recommended storage for excellent printing quality

HOW TO MAKE SPECIMENS

Printing temperature	260°C
Bed temperature	90°C
Top & bottom layer	3
Environmental Temperature	90°C

Infill	100%
Shell	2
Cooling fan	OFF

FLEXURAL TESTING SPECIMEN

ISO 178, GB/T 9341

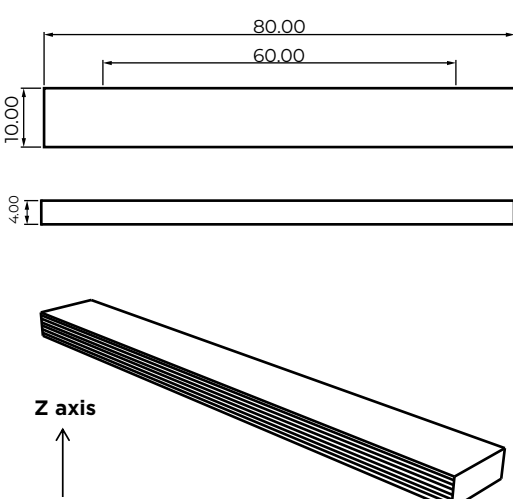

TENSILE TESTING SPECIMEN

ISO 527, GB/T 1040

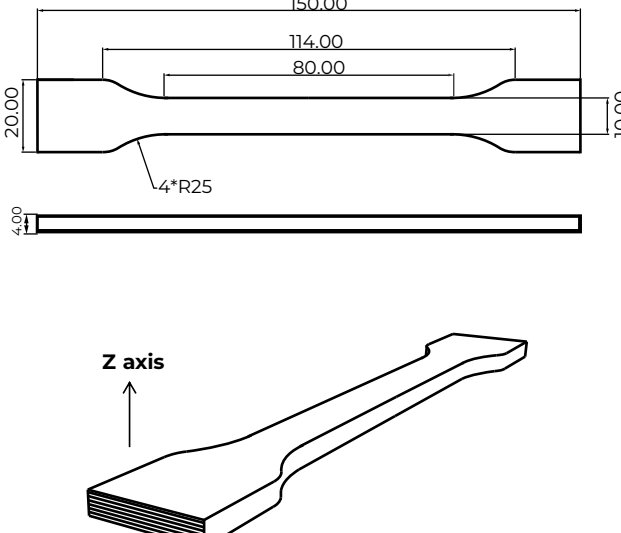

IMPACT TESTING SPECIMEN

ISO 179, GB/T 1043

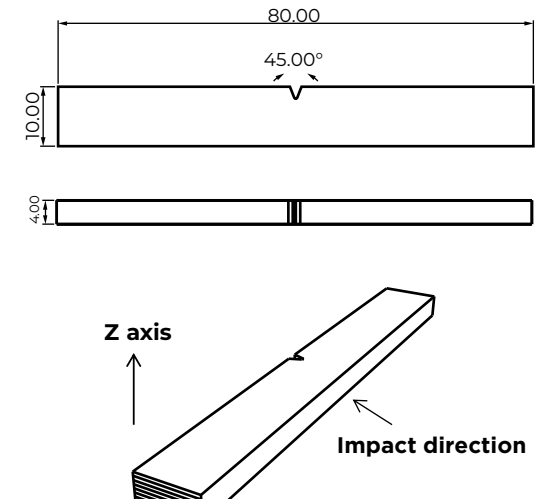

DISCLAIMER

The typical values presented in this data sheet are intended for reference and performance purposes only. They should not be used for design specifications or quality control purposes. Actual values may vary significantly with printing conditions. End-user performance of printed parts should not only depend on the material, but also on part design, environmental conditions, printing conditions, etc. Product specifications are subject to change without notice. Each user is responsible for determining the safety, lawfulness, technical suitability, and disposal/recycling practices of Polymaker™ materials for the intended application. Polymaker™ makes no warranty of any kind, unless announced separately, to the fitness for any use or application. Polymaker™ shall not be made liable for any damage, injury or loss induced from the use of Polymaker™ materials in any application.