

3D PRINTING FILAMENT DRYER

Series X: Tetras

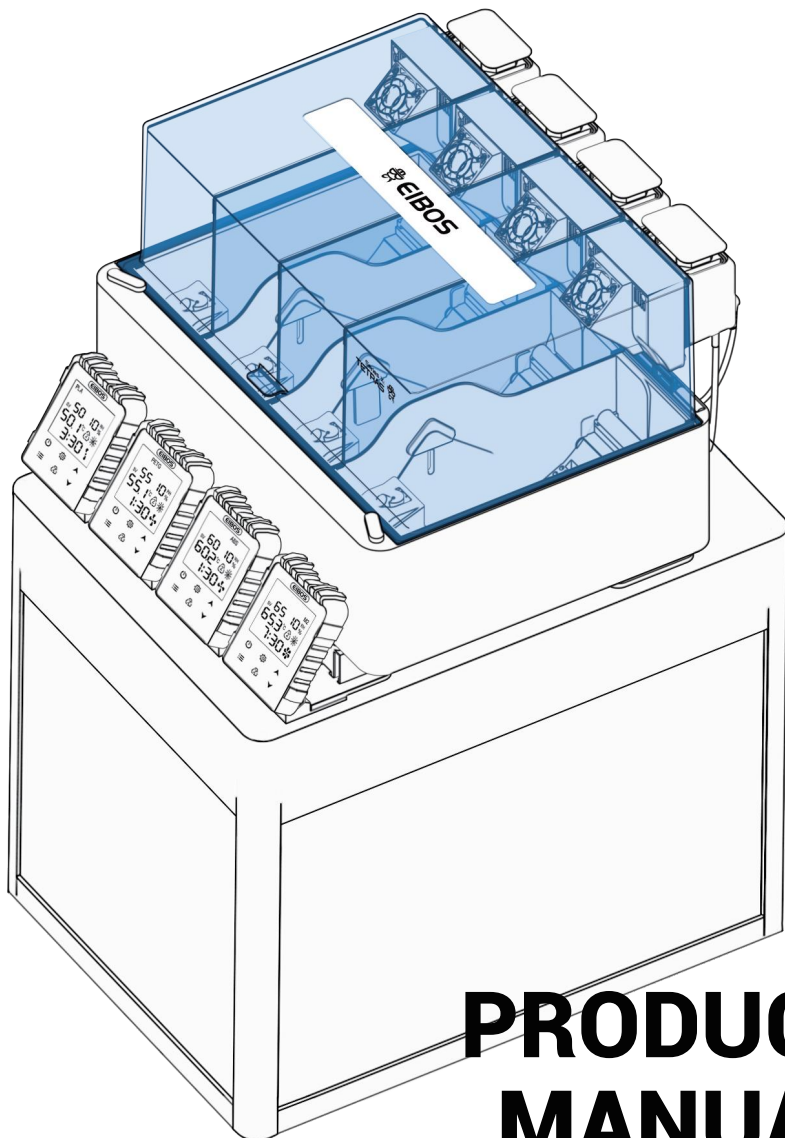

PRODUCT MANUAL



Video Assembly Process

Copyright @ 2025 EIBOS. All rights reserved

This language version of the manual is verified by the manufacturer (Original Instruction). No part of this publication, including pictures may be reproduced or made public, whether by printing, photocopying, microfilm, or by any other means whatsoever, without the prior written permission of EIBOS.

BEFORE USING

- Please refrain from inserting the power cord into the socket when the product is not in use.
- Take caution and avoid touching the heating vent to prevent burns.
- Do not insert any objects into the heating vent to avoid the risk of electric shock.
- For safety reasons, it is recommended to turn off the power supply when the product is unattended to prevent accidental fires.
- In the event of a product malfunction, kindly switch off the power and contact EIBOS or the authorized distributor, Do not attempt to repair it yourself.
- Please note that the pictures and instructions in this user manual may differ from the actual product.
- EIBOS shall not be held responsible for any direct or indirect damages resulting from product operation, modification, or accidents caused by user negligence.
- Do not open the acrylic cover when the high temperature has not cooled down after drying. The acrylic at hinge position may deform slightly due to temperature under load with time.
- The opening height of the sealing cover may vary slightly during use. This is normal and does not affect the performance or functionality of the product.

PRODUCT PARAMETERS

Input	<input type="checkbox"/> US : AC 120V 60Hz <input type="checkbox"/> EU / UK / AU : AC 230V 50Hz
Rated Power (Single)	60W
Rated Power (Whole Unit)	240W
Package Size	430x360x250mm
Upper Cover Mould Size	360x290x135mm
Net Weight	4.0kg
Total Weight	5.0kg
Overall height with AMS	280mm
Maximum height with cover open	424mm
Humidity Range	RH10%~99%
Temperature Range	20~65°C (Based on 25°C environment temperature)
Filament Size	φ1.75mm
Max Spool Size	Single Spools φ205×68mm

WARNINGS

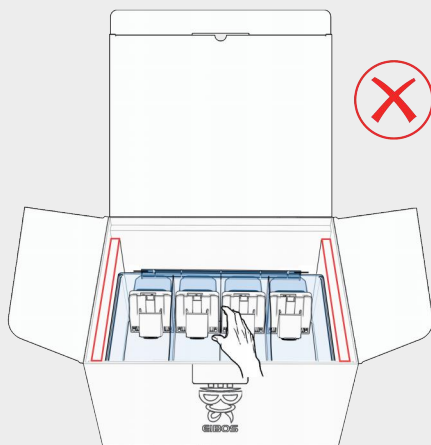

Please do not pick up the entire Main Device directly from the middle to avoid the acrylic partition in the middle from being debonded and damaged.

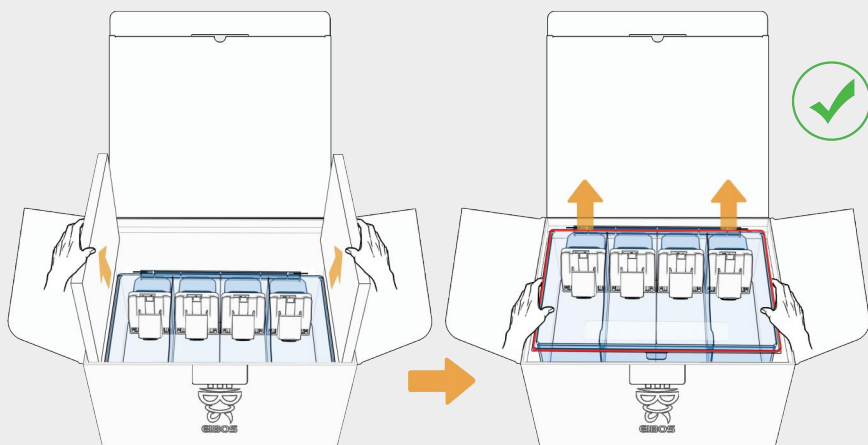

Please remove the EPE pearl cotton on the left and right sides first, and then pick up the entire Upper Cover Module from both sides.

PRODUCT OVERVIEW

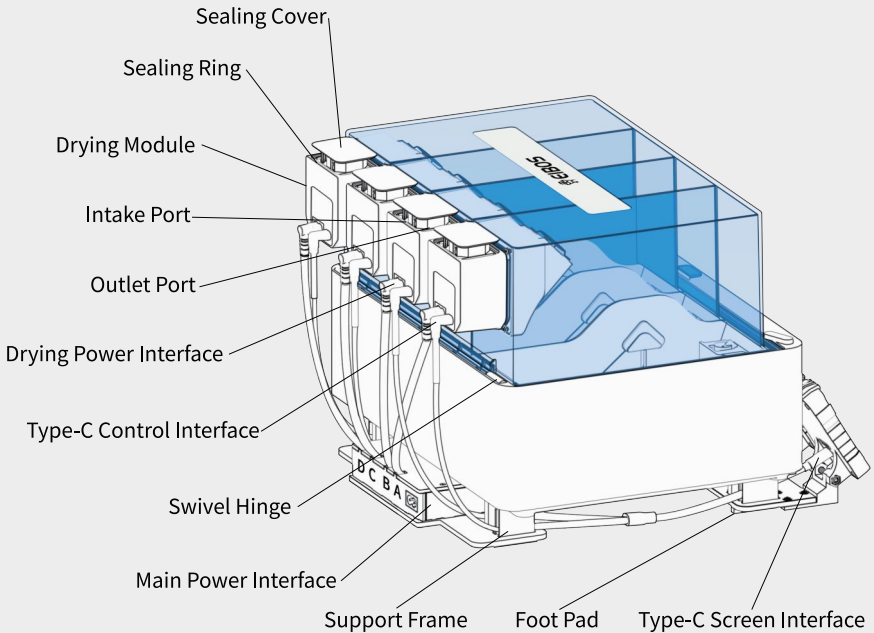
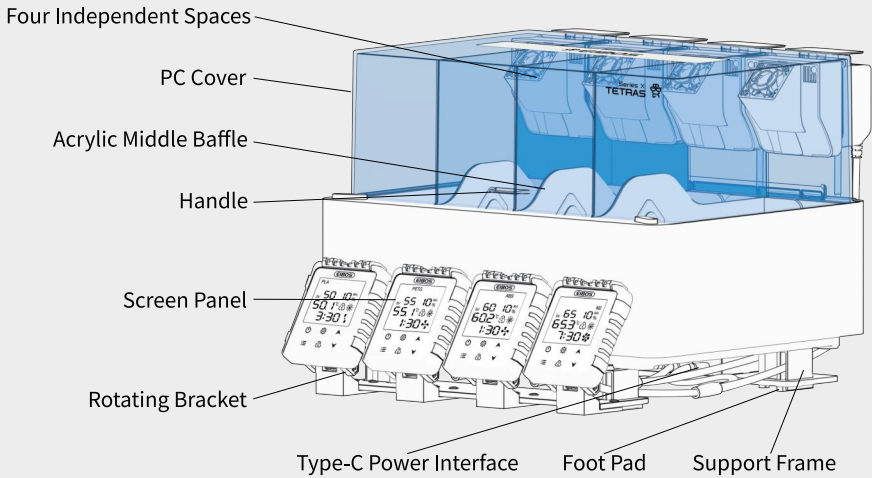

PARTS LIST

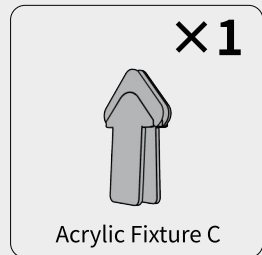
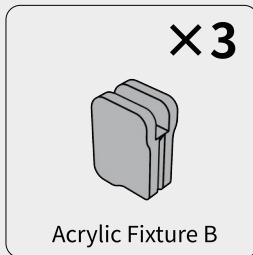
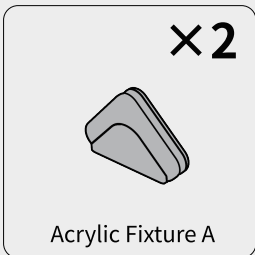
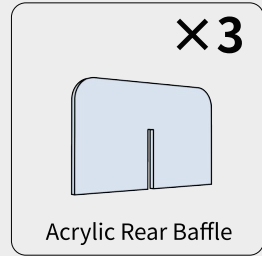
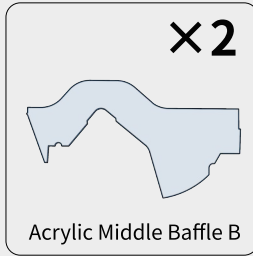
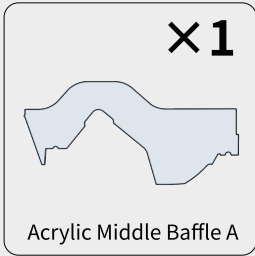
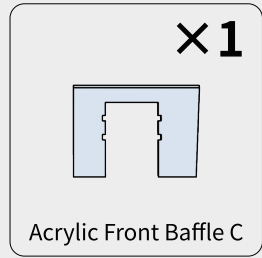
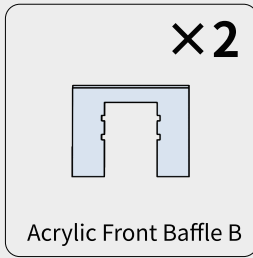
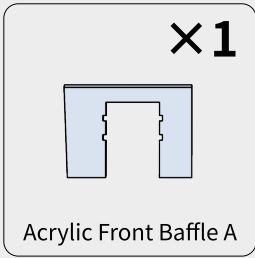
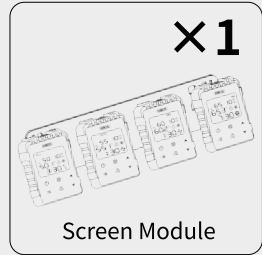
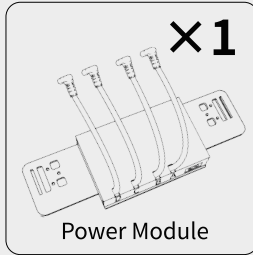
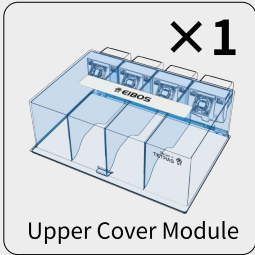

PARTS LIST

×4

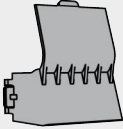

Feed Baffle

×4

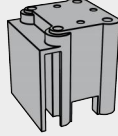

Support Frame

×8

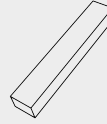

Foot Pad

×1

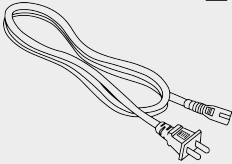

Power Cord

×4

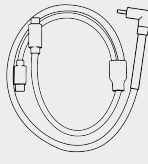

Type-C Cable

×1

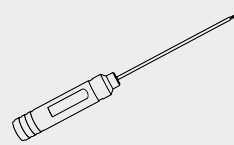

Allen Screwdriver

×12



Screws
M3 H12

×12



Screws
M3 H8

Spare parts

×1



Acrylic Fixture B

×1



Acrylic Fixture C

×2



Screws M3 H8

×2



Screws M3 H12

*Some parts in the accessory package are spare parts and not necessary for installation. The quantity of spare parts may vary, but it doesn't affect installation or usage.

ACCESSORIES INSTALLATION

STEP 1.

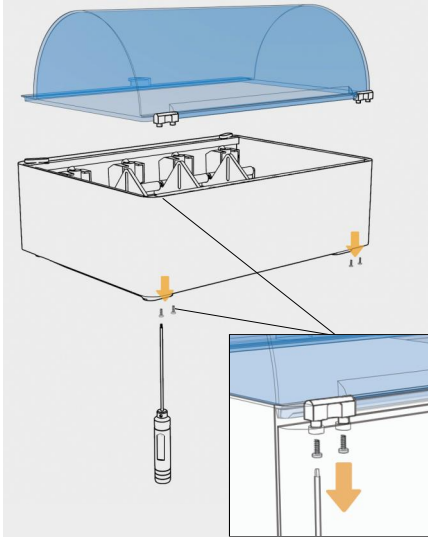

STEP 2.

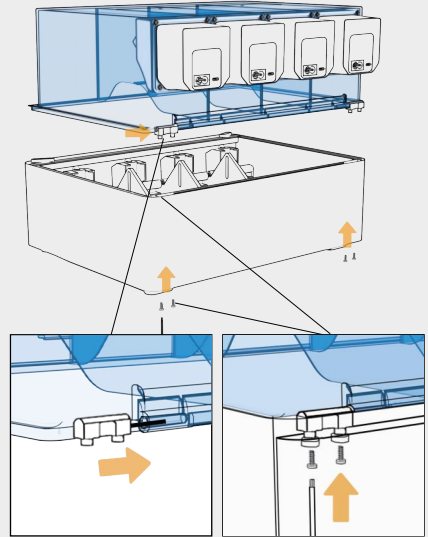

STEP 3.

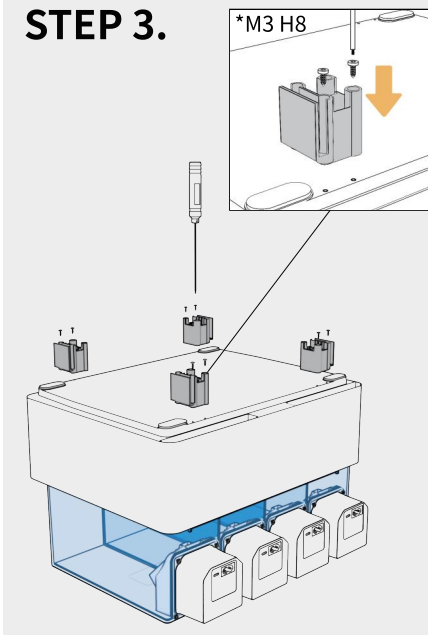

STEP 4.

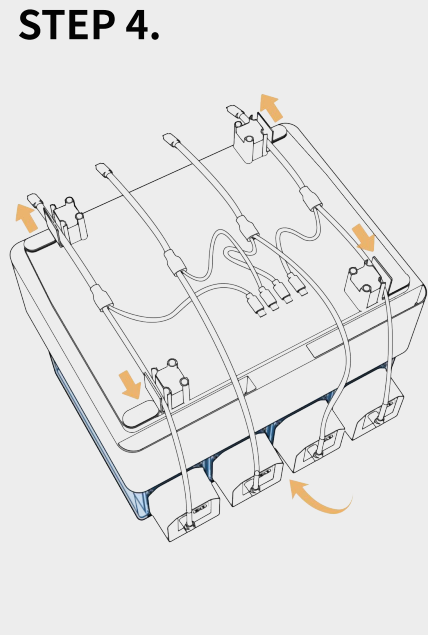

STEP 5.

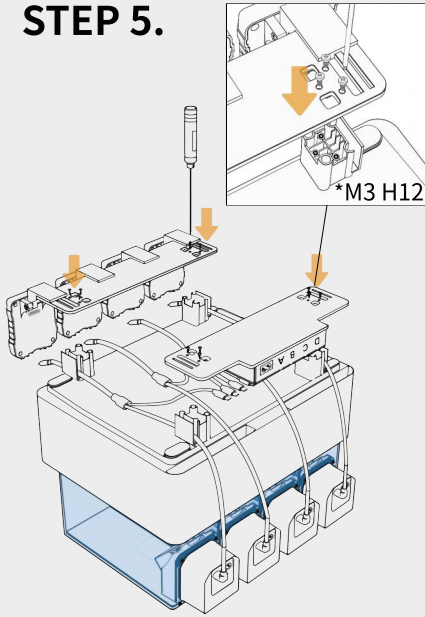

STEP 6.

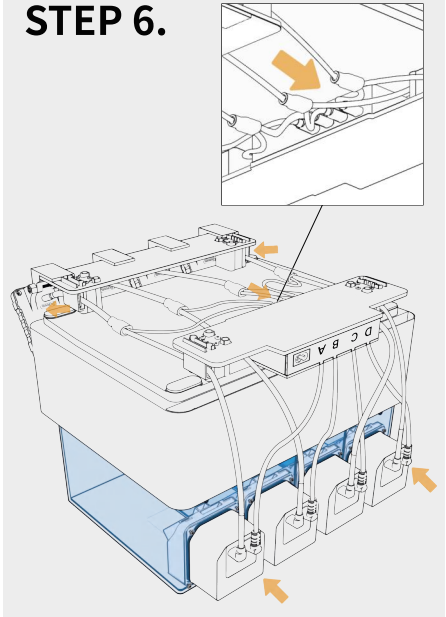

STEP 7.

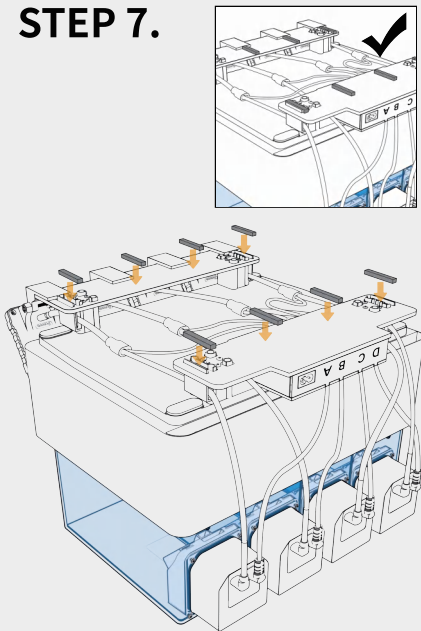

STEP 8.

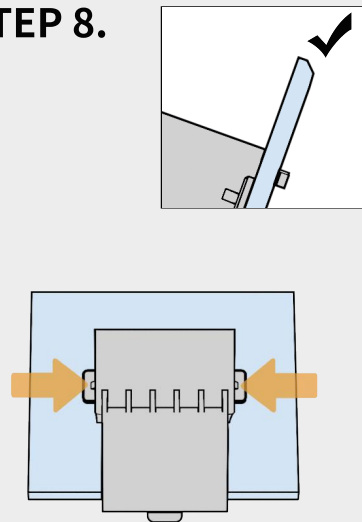

STEP 9.

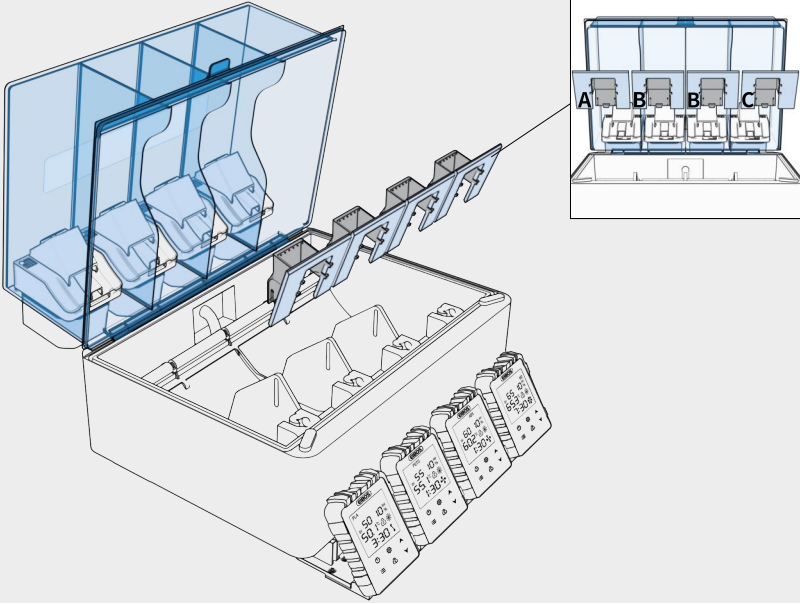

STEP 10.

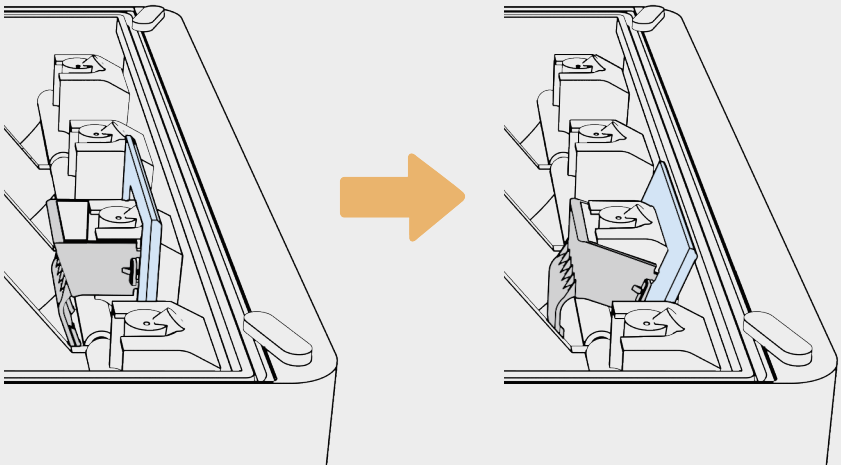

STEP 11.

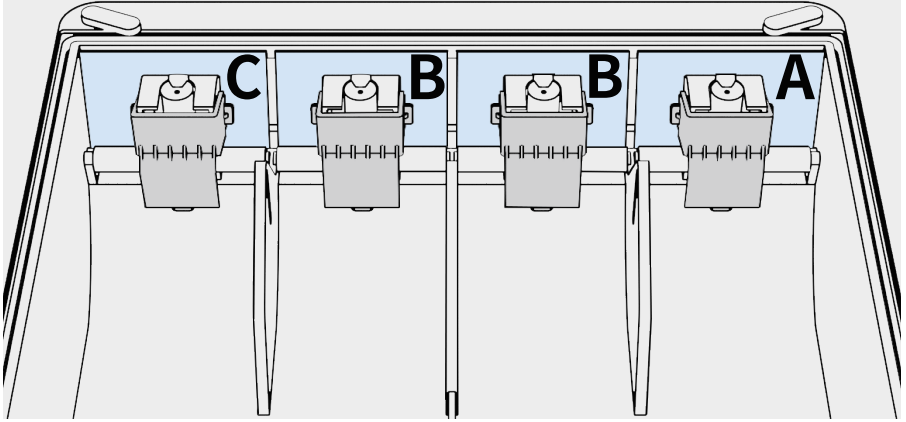

STEP 12.

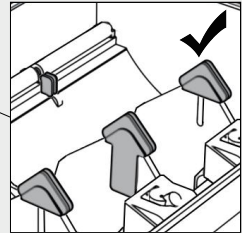
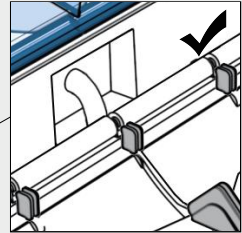
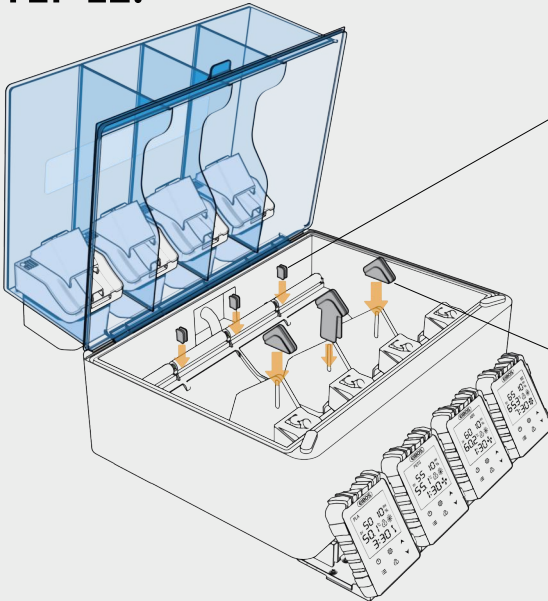

STEP 13.

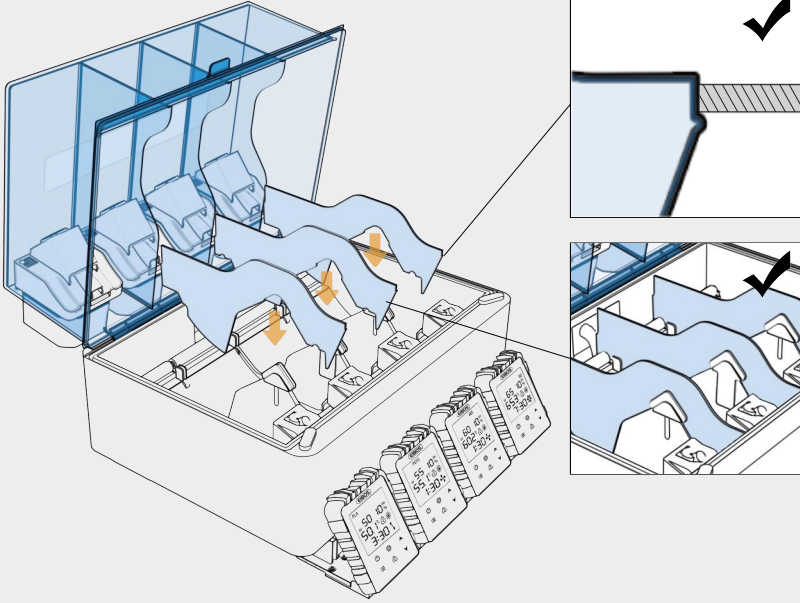

STEP 14.

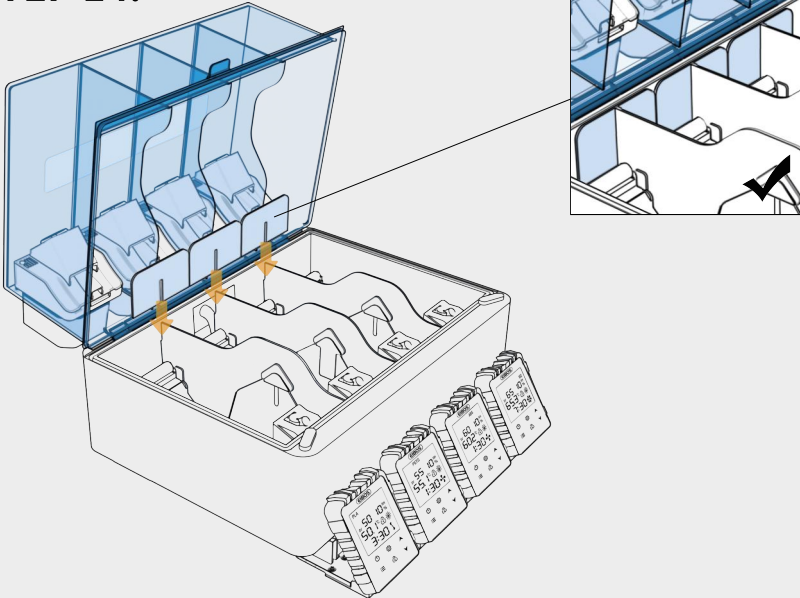

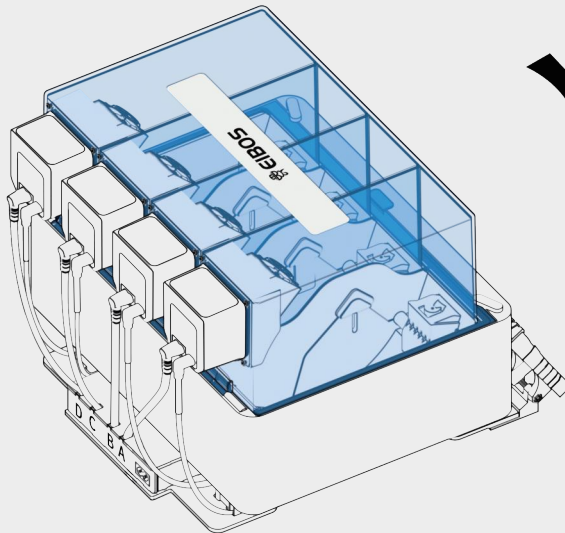
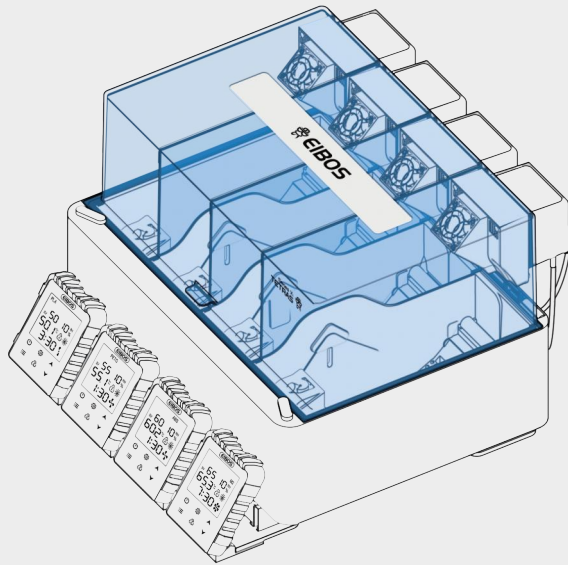

INTRODUCTION OF SCREEN



* Before connecting the power cord, please ensure that the rated voltage on the nameplate at the back of the unit matches your local power supply. Using an incorrect voltage may result in excessive or insufficient heating, potentially damaging the device.

■ Power On/Off

After connecting the power cord, press the "Power On/Off " button to turn the device on or off.

Press the "Power On/Off " button once to enter Humidity Mode.

Press the "Power On/Off " button twice to completely shut down the device.

To restore factory settings, press and hold the "Power On/Off " button for 5 seconds.

■ Material Selection

Press the "Option " button, then use the "Up " / "Down " keys to select the filament type.

Each material corresponds to a preset set of drying parameters. Available options include PLA, ABS, PETG, TPU, and custom setting M1 and M2. The customize changes will be recorded.

* The default drying parameters for filament types are for reference only. We recommend adjusting settings based on the filament's moisture content and heat deflection temperature to avoid damage.

■ Drying Settings

Press the "Setting 

Drying temperature range: 20°C – 65°C

Drying time range: 30 minutes – 24 hours

Drying power levels: Low / Medium / High

Mode selection:

When "— —" displayed at humidity level: Drying Mode Only — the device shuts down automatically after drying is complete.

When humidity value displayed: Humidity Mode on after the drying process is finished. The device activates drying automatically when ambient humidity exceeds the humidity value preset and stops 1 hour after the target humidity is reached.

To switch between °C and °F, press and hold the "Setting 

■ Second-Stage Drying Mode

The two-stage heating allows for optimized drying and printing. Use the first stage to thoroughly dry the filament. Then, during the second stage, maintain a slightly lower temperature to support stable filament feeding and printing performance.

Press the "Stage 2 

Press and hold the "Stage 2 

Drying temperature range: 20°C – 65°C.

Drying time range: 30 minutes – 24 hours, or "— —" for unlimited timer.

Drying power: Low / Medium / High.

When the desired parameter blinks, use the "Up 

■ Automatic Sealing Cover Operation

When the drying function is active, the sealing cover automatically opens and stays open to allow airflow during drying.

After drying is complete, the cover automatically closes to seal the chamber and prevent moisture from re-entering the filament.

In case of sudden power loss or external interference causing the cover to fall or remain open, you can manually adjust it.

Long press the "Down ▼" button: the cover will descend for 2 seconds. Press again for another 2-second descent; repeat as needed to fully close the cover.







Long press the "Up ▲" button: the cover will rise for 8 seconds.

As we want to make the chamber be as airtight as possible, you may hear some 'clicking' sound when the door is closing closes.

*During the drying process, the sealing cover must remain open. If manually closed, heat generated by the internal elements will not dissipate properly, risking damage to the device.

ADDITIONAL INFORMATION

DATA SHEET

Filament	PLA	PETG	ABS	TPU	M1	M2
Temperature	50°C	55°C	60°C	60°C	60°C	65°C
Timer	4H	2H	2H	4H	6H	8H
Heating Level						

SIZE REFERENCE

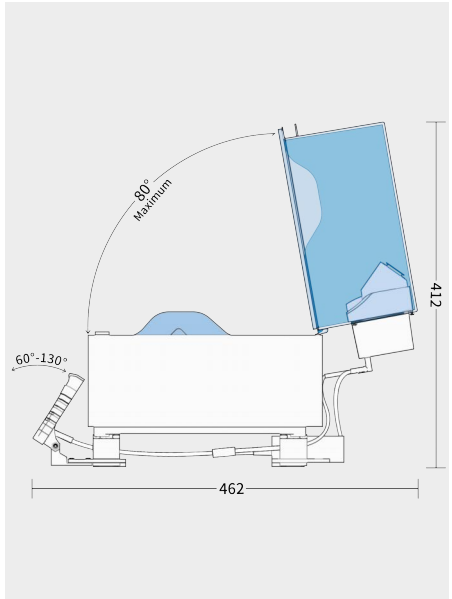
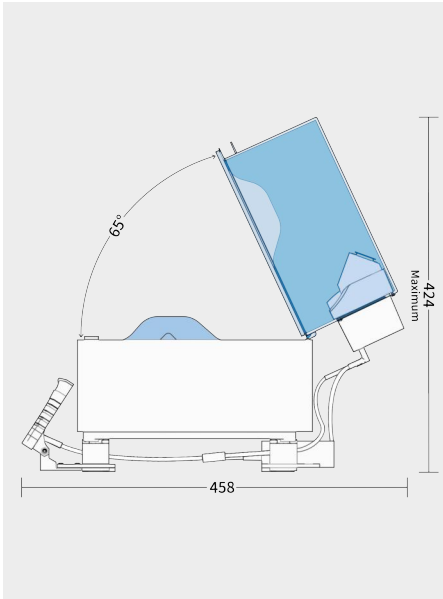
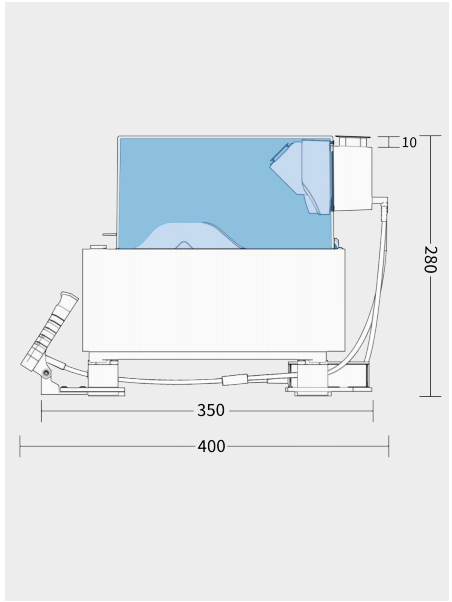
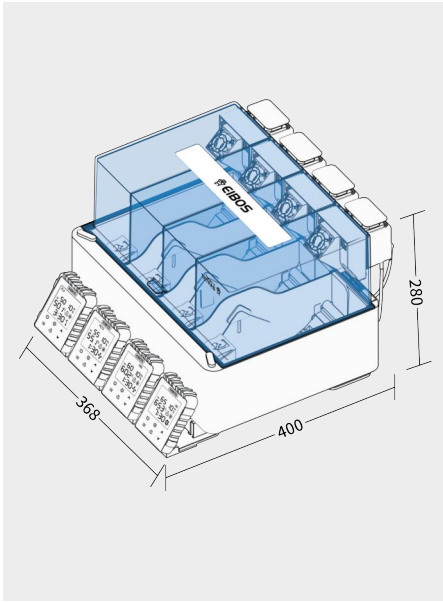

■ Q1: The temperature or humidity is not accurate.

The temperature or humidity displayed on the screen are the values from the sensor's location and do not represent the temperature or humidity at any other position inside the box. The temperature at the sensor's location approximates the temperature near the filament, but it does not fully represent the temperature of the filament. When using an external thermometer to measure temperature, it is recommended to use a laboratory-grade thermometer specifically designed for measuring AIR temperature. Household indoor thermometers, infrared thermometers, food thermometers, and similar devices are not suitable for measuring the temperature of this equipment. The humidity value is only intended as a reference for changes in the internal environmental humidity of the product and does not represent the moisture content or level of the 3D printing filament.

■ Q2: The temperature cannot reach the set value of 65 °C.

When setting the temperature to 65 °C, please ensure that the heating level is set to the maximum (Highest ). The heating time should be set for more than 1 hour. However, please note that if your ambient temperature is too low, it may not be possible to reach 65 °C.

■ Q3: The fan alarm is displaying on the screen.

When the fan icon  is blinking on the screen, it indicates an error in the fan system, possibly due to unstable wiring connections or interference with the fan component by foreign objects. If the fan alarm occurs, please contact EIBOS support email promptly for assistance.

■ Q4: The temperature is displaying "LL" on the screen.

When the temperature displays 'LL' on the screen, it is due to a poor connection of the sensor interface, resulting in inaccurate temperature readings. Therefore, if this error occurs, please contact EIBOS support email promptly for assistance.

■ Q5: Will incorrect Type-C connections affect device functionality?

Tetras can only work properly under normal wiring.

Wrong wiring method may cause the machine to not work properly.

There may be two different situations:

Case 1: The port of Type-C does not match the corresponding port of the device (Screen-Power-Control). In this case, Tetras will not be started.

Case 2: Type-C does not link the components according to the cavity. In this case, the device can be turned on. The devices connected by Type-C will form a control group. Take the following situation as an example.

eg1. The 'Control' of cavity A is connected to the 'Control' interface of cavity B, then the parameters of cavity B will be set through the screen of cavity A.

eg2. The Screen of cavity C is connected to the Screen of cavity D, then the parameters of cavity C will be set through the screen of cavity D.

■ Q6: Can I print while drying in all three different modes (Single-Stage, Second-Stage, and Humidity Mode)?

Yes.

EIBOS Series X: Tetras is compatible with the function of printing and drying in all three stages.

■ Q7: What is the purpose of four independent chambers?

In our actual use, we realized that the choice of filament is often different when using AMS to print. This difference is often not simply reflected in the type of filament, but more importantly, for example the age of the filament, the environment in which the filament is stored, and the quality of filament of different brands.

Dividing the AMS into four independent chambers allows users to make better choices --- this choice can be made according to the actual situation and the status of the filaments. At the same time, the independent control system also allow users to set more matching parameters such as temperature and time of each chamber.

■ Q8: Can I adjust the viewing angle of the Screen Module?

Yes, the viewing angle of the screen can be adjusted. Each screen is independent, user can adjust the angle for each screen base on their need. The Screen adjustable angle is from 60°- 130°.

■ Q9: What is the maximum lid opening angle?

The Maximum lid opening angle is 80°. We have using a damping hinge in the structure. When opening and closing at this angle, the upper cover will not close automatically.

■ Q10: Why 65°C is the highest temperature?

Since the label on the edge of Bambu lab's reel requires the drying temperature of the filaments to be less than 70°C, we believe that this is the temperature that the filament spool can withstand, under the test standard. In order to ensure the safety of the filaments and the spool, we set the upper limit of the temperature to 65°C to ensure the stability of the AMS cavity and filaments.

■ Q11: Does Tetras support wide voltage input?

No, EIBOS Series X: Tetra is not wide voltage compatible. We offer two different input voltage options: 110V and 220V.

■ Q12: What is the total power consumption when all chambers are active?

If only one cavity is in working state, the maximum power is 60W. When all four cavities are turned on, the maximum power is 240W.

■ Q13: If one control panel fails or is paused, will it affect the others?

No.

Because each screen is relatively independent, the issue of one screen will not affect other screens or controls.



SHENZHEN EIBOS CHUANGGOU TECH CO.,LTD

E-MAIL

PRE-SALES, LOGISTICS AND TECHNICAL SUPPORT
support@eibos3d.com

RESELLING AND BUSINESS COOPERATION
eibos@eibos3d.com

WEBSITE

www.eibos3d.com
shop.eibos3d.com