

INSTRUCTION MANUAL

Remote-controlled air filtration kit for AMS-
compatible BambuLAB P1S / X1 / X1C

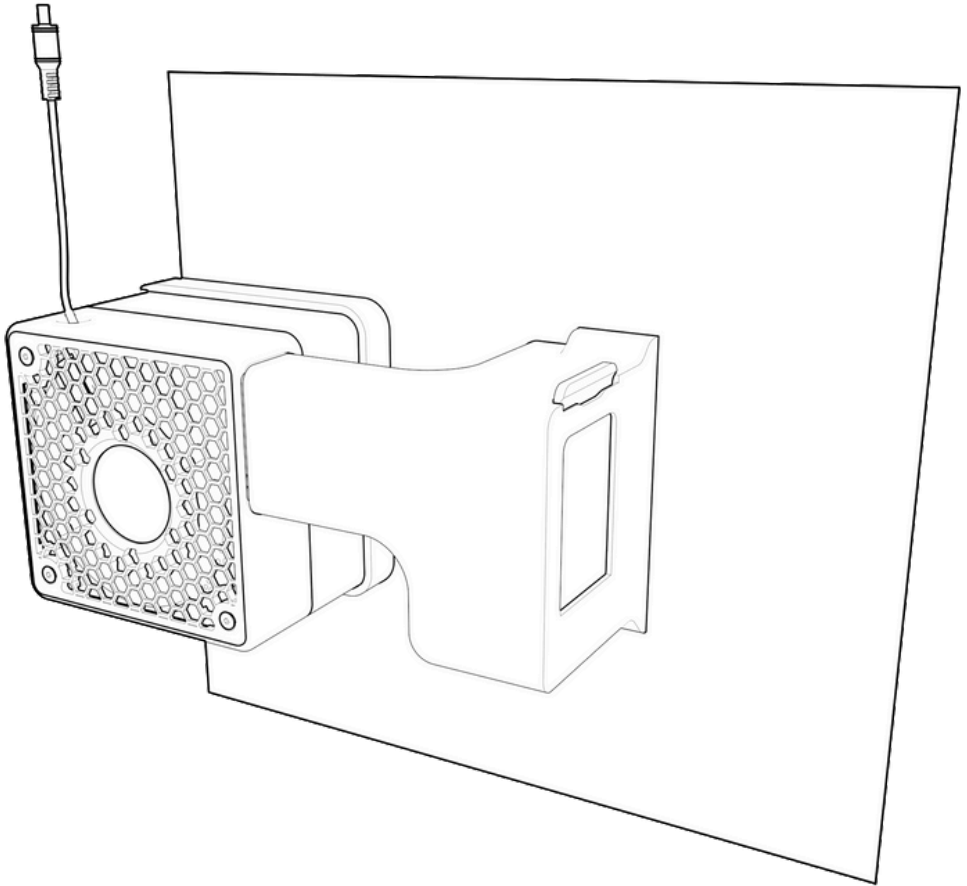

INSTALLATION RECOMMENDATIONS

To assemble the kit, you will need to print the structural components. You can print these parts by accessing the links provided in the email you received after your order or by visiting the following address:

<https://www.alveo3d.com/download-kit-bambulab/>

The installation is carried out directly on the machine's rear panel at the location of the existing fan. No modifications to the machine are required. The kit is compatible with AMS models on P1S, X1, and X1C.

Kit Design

The BambuLAB kit is designed to provide maximum protection for users without requiring structural modifications or enclosing the machine. Print the parts using PETG or any filament capable of withstanding a maximum temperature of 60°C.

System Performance

The system, leveraging the P3DR model, ensures high efficiency in treating harmful emissions, including ultrafine particles and volatile organic compounds (VOCs).

The selected filter and fan (BLHP2432_H12) offer the following benefits:

1. Minimized noise levels.
2. Sufficient airflow to maintain lower pressure in the printing chamber.
3. Prevention of polluted air leaks outside the machine.

The two-part design includes a guide to redirect recycled air back into the machine through the filament waste extraction opening.

Additional Advantages :

Thermal Recycling

The guide helps maintain stable temperatures within the chamber, essential for printing filaments that require high temperatures. This compensates for the automatic shutdown of the original filtration system.

Exhaust Hatch

A dedicated hatch efficiently evacuates air for filaments requiring lower printing temperatures.

External Positioning

The system is installed outside the enclosure to prevent potential conflicts with the machine's internal mechanical components while ensuring optimal air pressure management.

SAFETY INSTRUCTIONS

Read the guidelines before use.

1. Power on the fan only after assembling the device with protective grills to avoid injury.
2. Use only recommended electrical voltages to power the system to prevent damage to electronic components.
3. Avoid contact with the electronic board when it is powered.
4. Observe the following operating conditions:
 - Maximum temperature: 60°C
 - Optimal temperature: 0-40°C

MATERIALS PROVIDED

Materials Provided in this Kit:

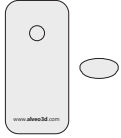

- Remote and IR receiver (battey included)



- 24V power supply

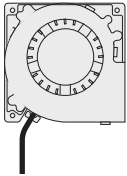

- BLHP2432_H12 Blower

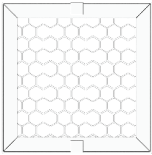

- P3D-R Filter



- 3X M4x50mm countersunk screws



- M4 nuts x4



- Metal self-tapping screws, Phillips head, 12 mm x2



- 1X M4x12mm countersunk screws



- O-ring NBR70 X 2



- EPDM sealing cord 50cm x 1



- Magnets 30x10x2mm x3



- Waterproof plastic bag (for used filter)

MATERIALS NEEDED

Materials Needed (Not Provided):



- 2.5 mm Hex Allen key (for M4 screws)

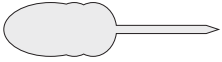

- Phillips screwdriver



- Scissors

Additional Items for Filter Replacement.

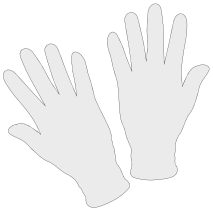

- Gloves

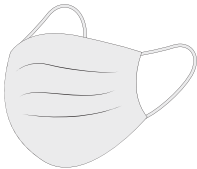

- Minimum FFP2 mask

1. MOUNTING THE CASING

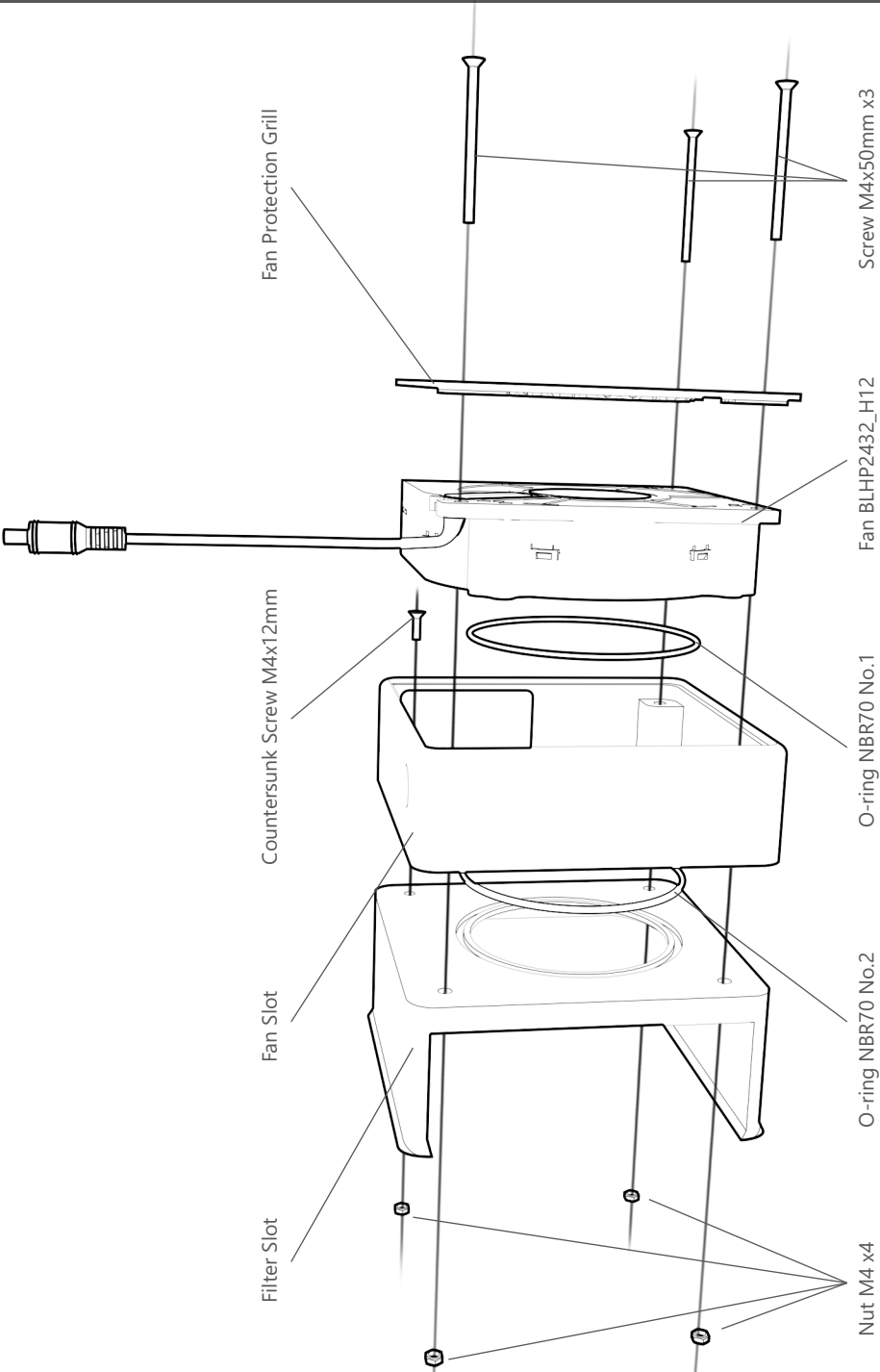

2. MOUNTING THE CASING SUPPORT ON THE PANEL

1. **Locate the Holes:** Identify the holes on the rear panel intended for installing the filtration system support.
2. **Attach the Support:** Use 12mm self-drilling metal screws to secure the support. The new system is designed to be installed directly on the original setup without modifications.

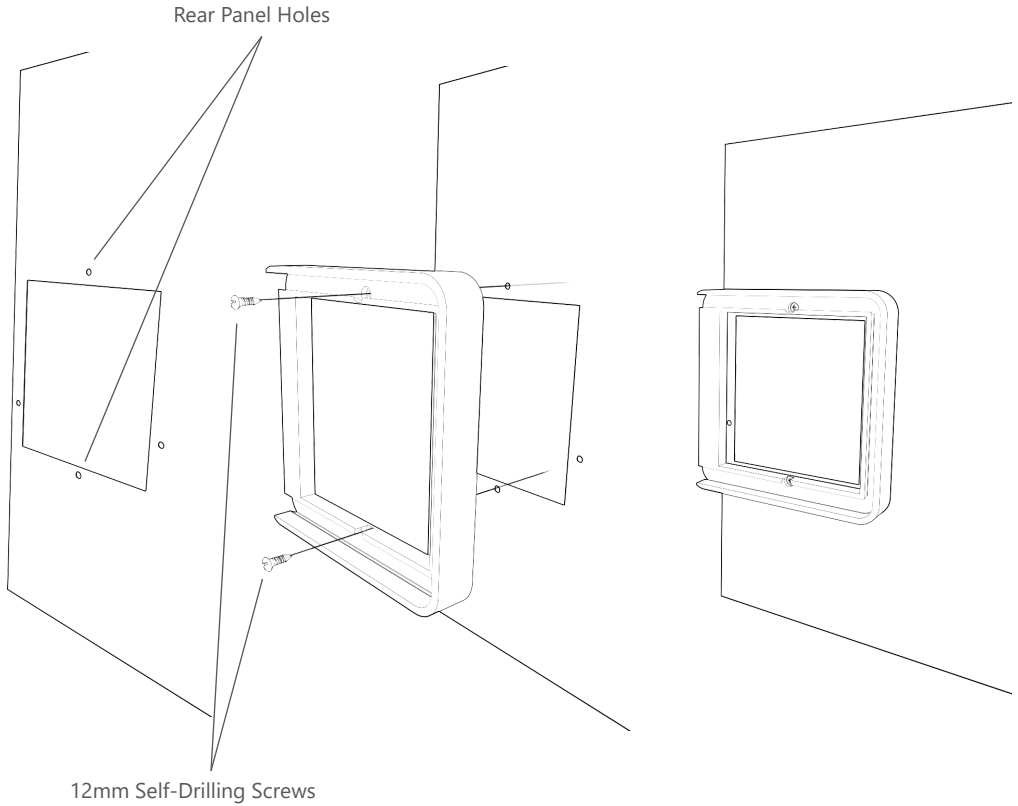

3. INSTALLATION OF THE CASING ON THE SUPPORT

1. Mount the Filtration Casing: Place it on the support attached to the rear panel.
2. Slide the Casing: Align it properly and slide it into the support rail

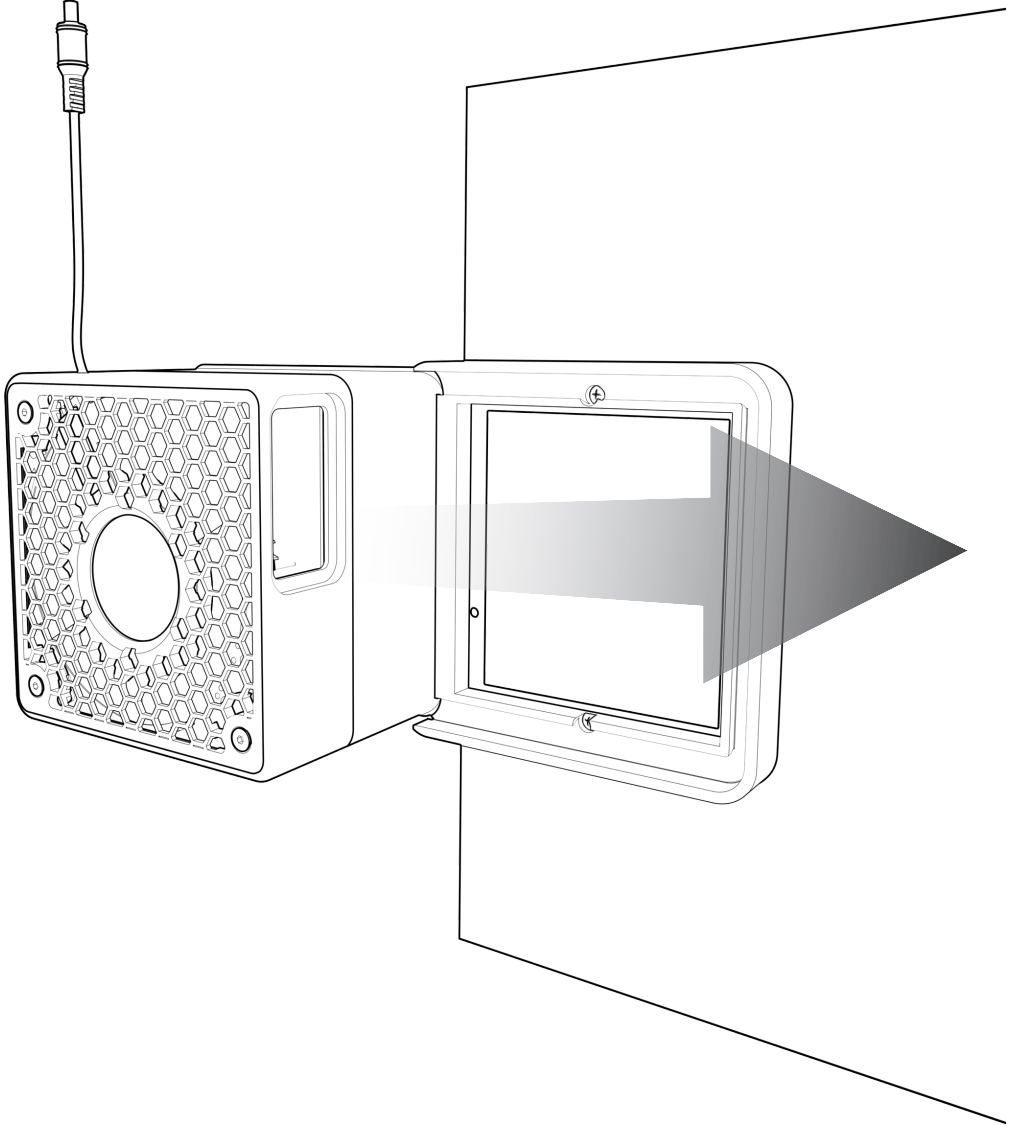

4. INSERTION DU FILTRE P3DR

1. Insert the filter with the activated carbon side facing the fan.
2. Push the filter all the way to the stop to ensure correct positioning.

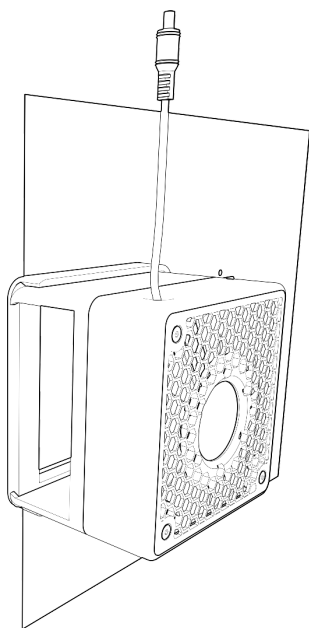

1.
Insert the Filter

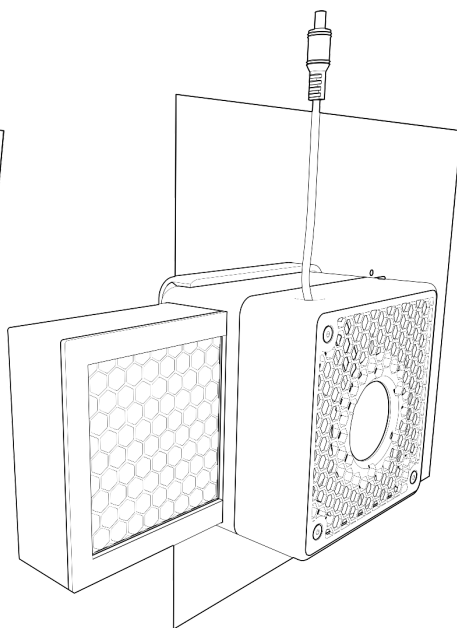

2.
Activated Carbon Side:
Ensure it is facing the fan

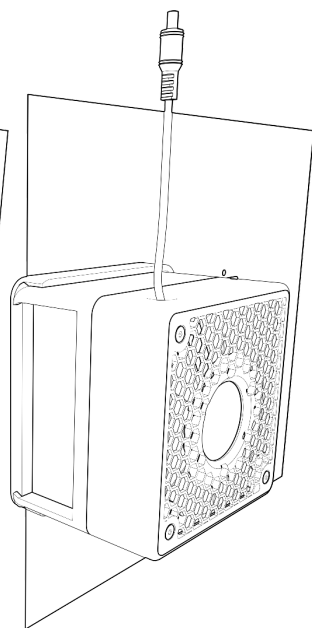

3.
Push the Filter:
Insert it fully until
it reaches the stop

5. GUIDE DE RECYCLAGE

1. Prepare the EPDM seals on the guide by cutting two pieces of sufficient length to cover the designated areas.
2. Place the magnets in the designated slots and secure them with strong adhesive to ensure they stay in place.

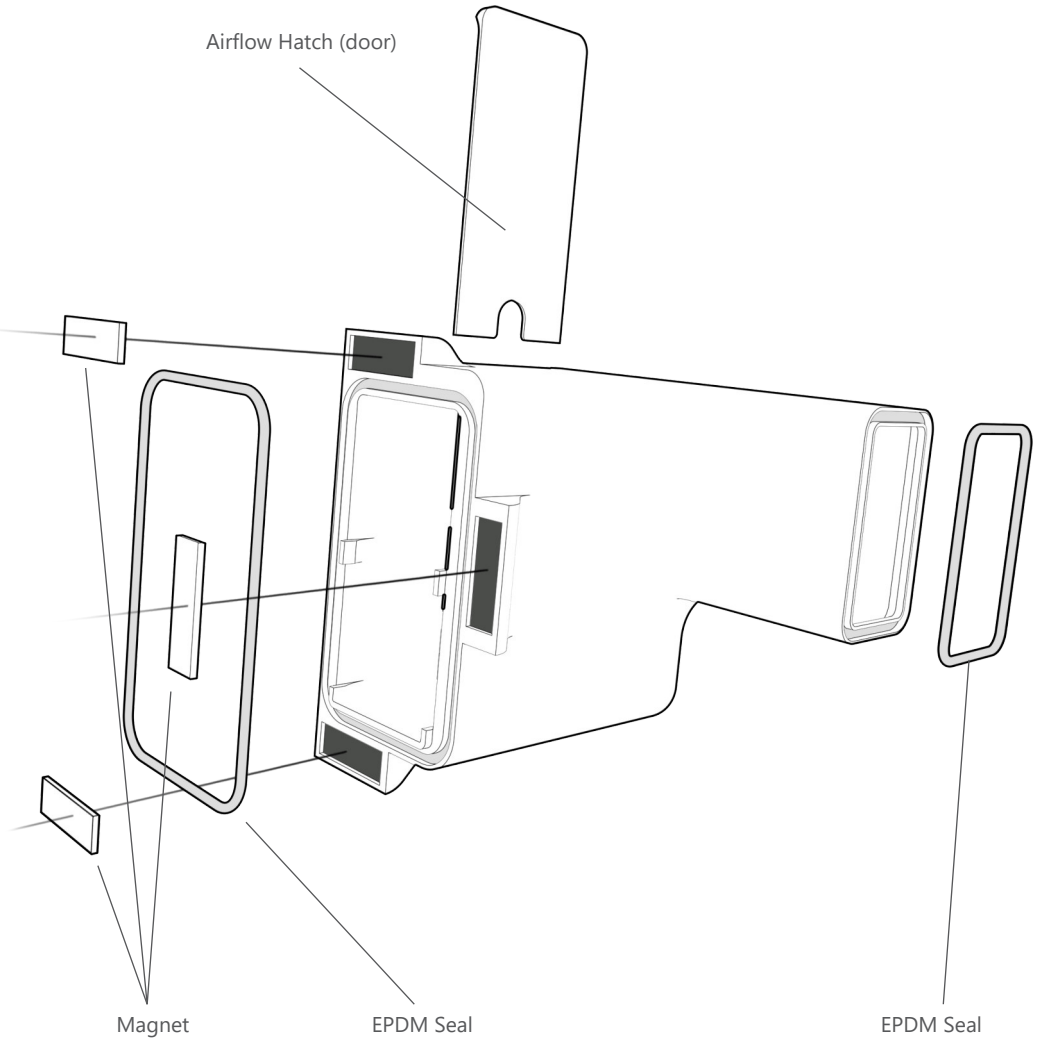

6. POSITIONING OF THE RECYCLING GUIDE

Position the recycling guide on the rear panel, ensuring it is properly placed to guarantee an optimal seal between the guide and the filtration casing.

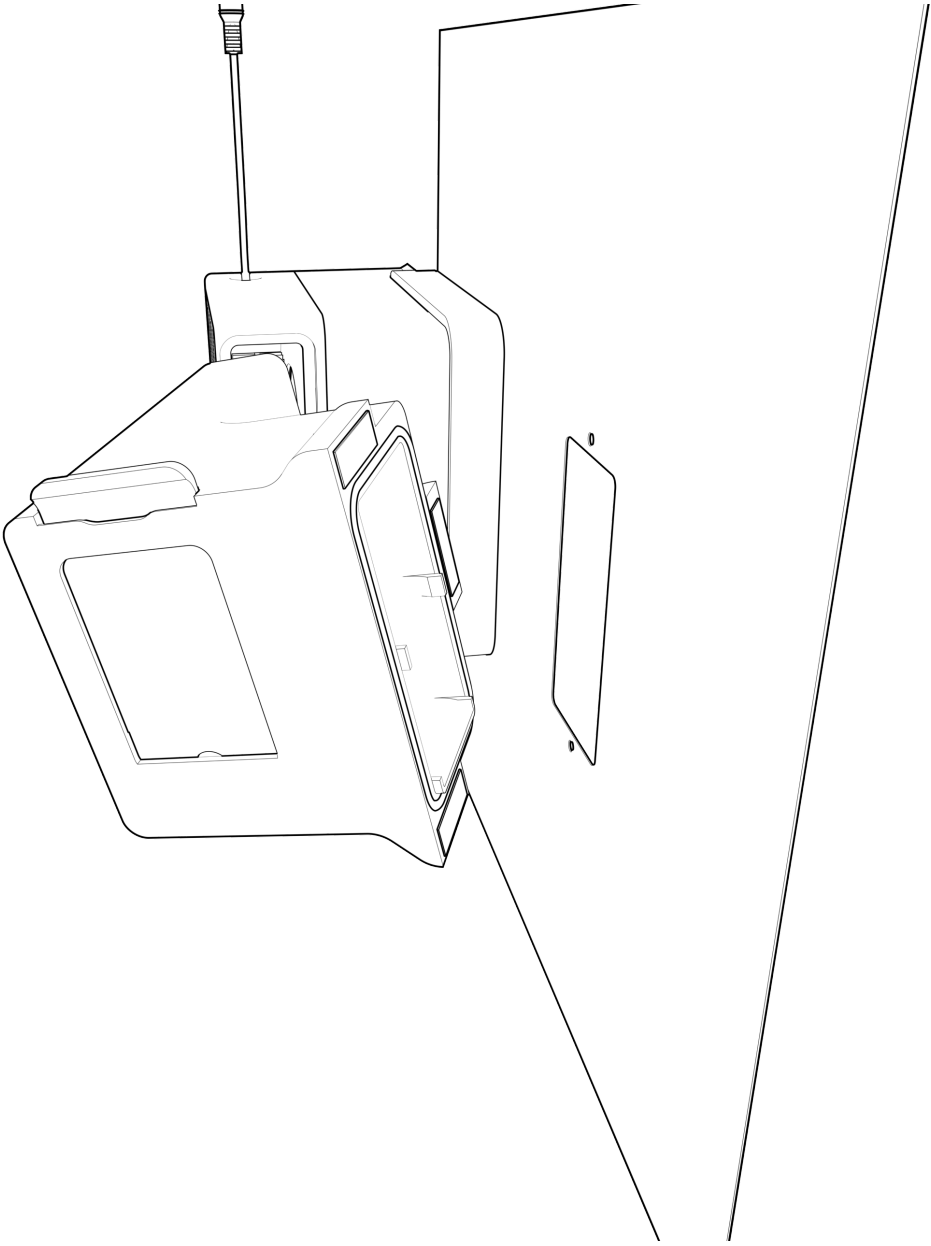

7. RECYCLING GUIDE PINS

Also check the proper positioning of the guide's ergonomic features to ensure a perfect seal.

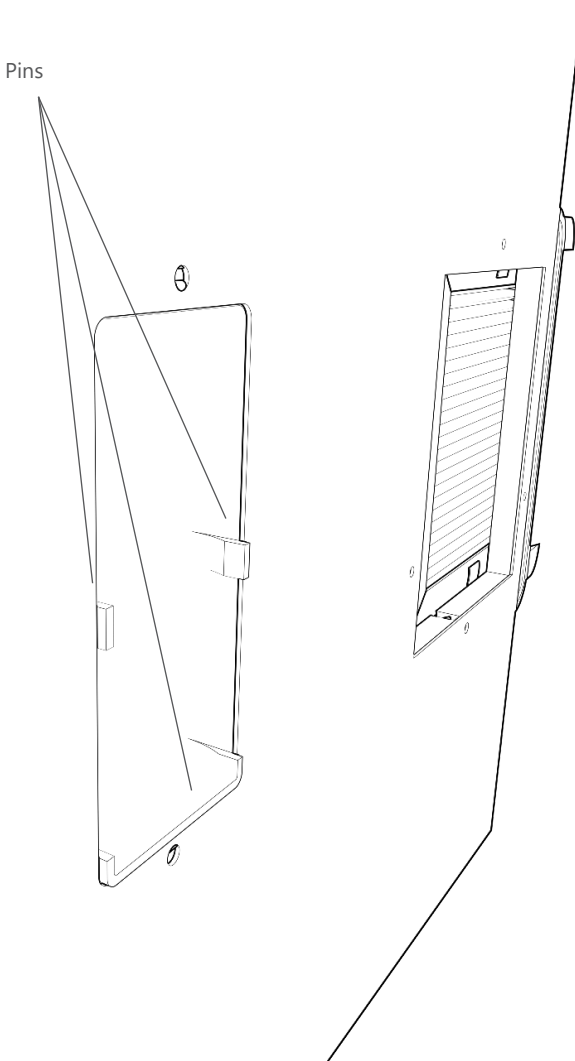

8. SEALING OF THE RECYCLING GUIDE

Check that the casing is correctly positioned against the stop on the support and that the recycling guide fits perfectly into the designated space on the casing

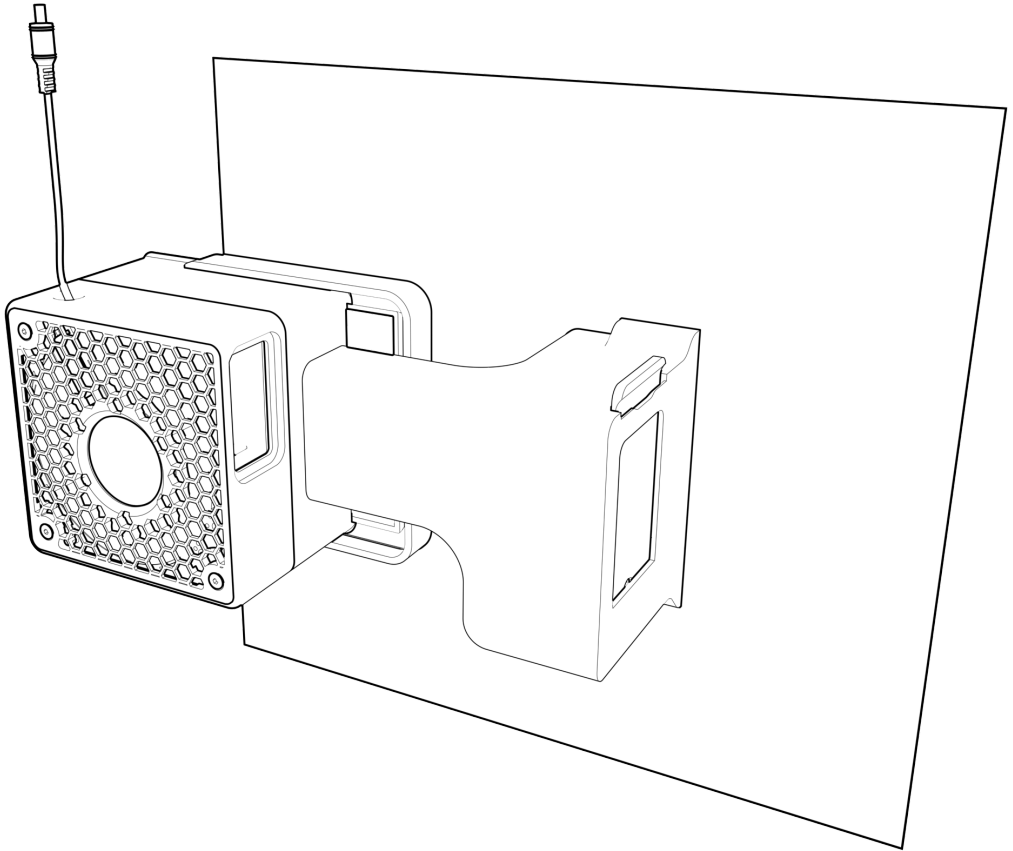

9. AIRFLOW MANAGEMENT USING THE DOOR:

Use the door to manage the air according to the filaments:

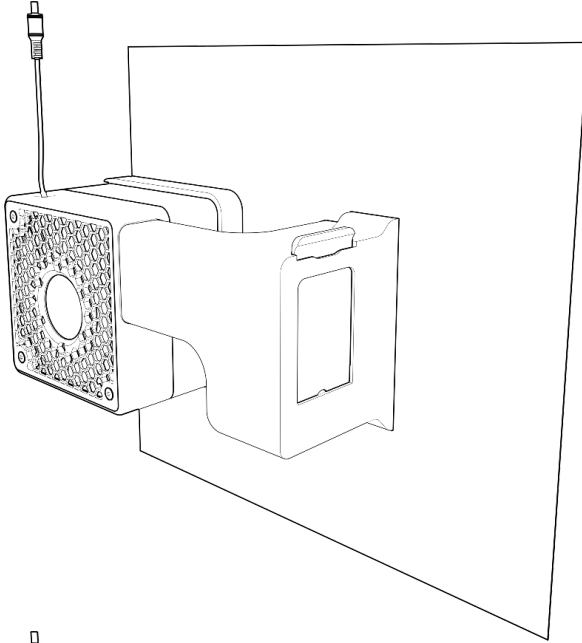

1.
Closed trap :
ABS
ASA
PC
Nylon

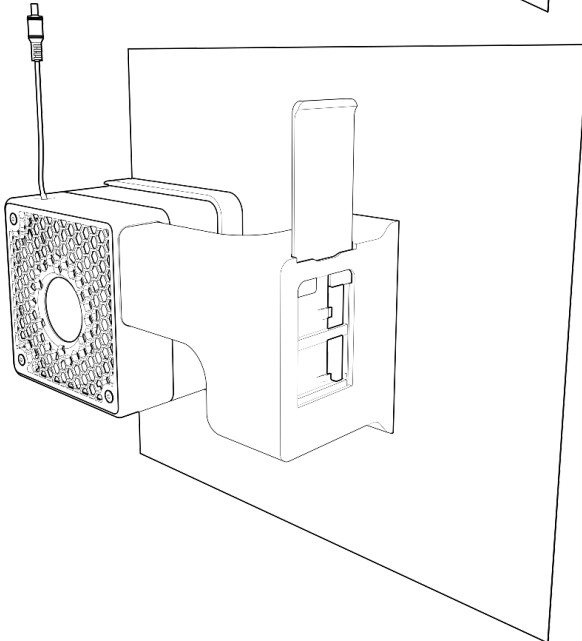

2.
Semi-open trap :
PETG

Open trap :
PLA
TPU

10. ELECTRICAL CONNECTIONS:

1. Connect the IR receiver to the male connector of the blower.
2. Plug the 24V power supply into the female connector of the IR receiver.



1.
Blower -> IR Receiver

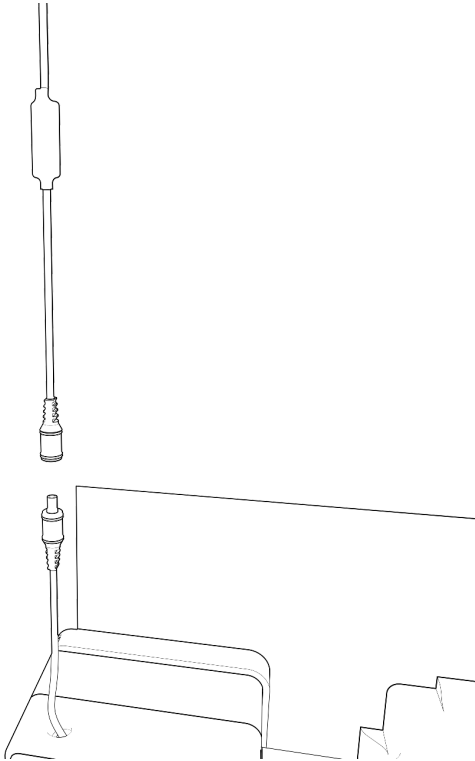

2.
IR Receiver -> 24V Power supply



FILTER REPLACEMENT

Filter lifetime sheet

The lifespan of a P3DR filter depends on several factors such as the type of plastic used for printing, melting temperature, concentration of nanoparticles, VOCs, and humidity levels. We recommend replacing the filter according to the following table:

Remplacement du filtre	Intensive Use	Occasional Use
	Every 3 months	Every 6 months

We recommend not exceeding 600 hours of use per filter.

Filter Replacement Tracking:

	Date
Date d'achat	
Remplacement 1	
Remplacement 2	
Remplacement 3	
Remplacement 4	
Remplacement 5	
Remplacement 6	
Remplacement 7	
Remplacement 8	
Remplacement 9	
Remplacement 10	

Breathe Easy! You're Filtering!

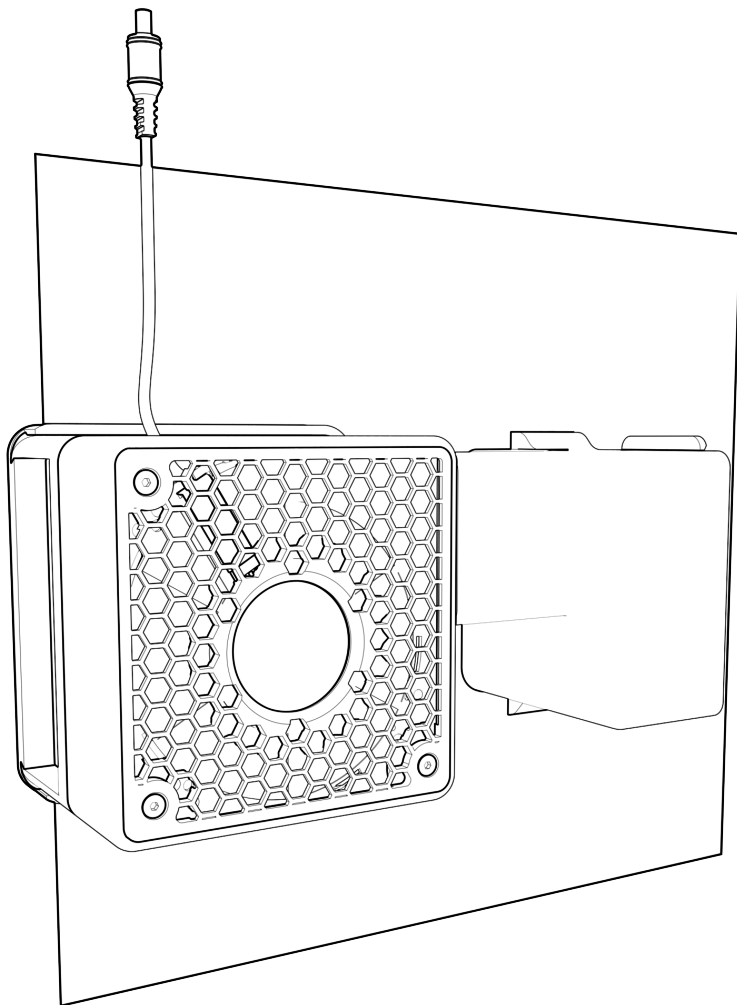

Designed in France

ALVEO3D

460 Rue de la Leysse
73000 Chambéry
France

contact@alveo3d.com
