

INSTRUCTION MANUAL

Electronic controller board V2 for filtering system ALVEO3D

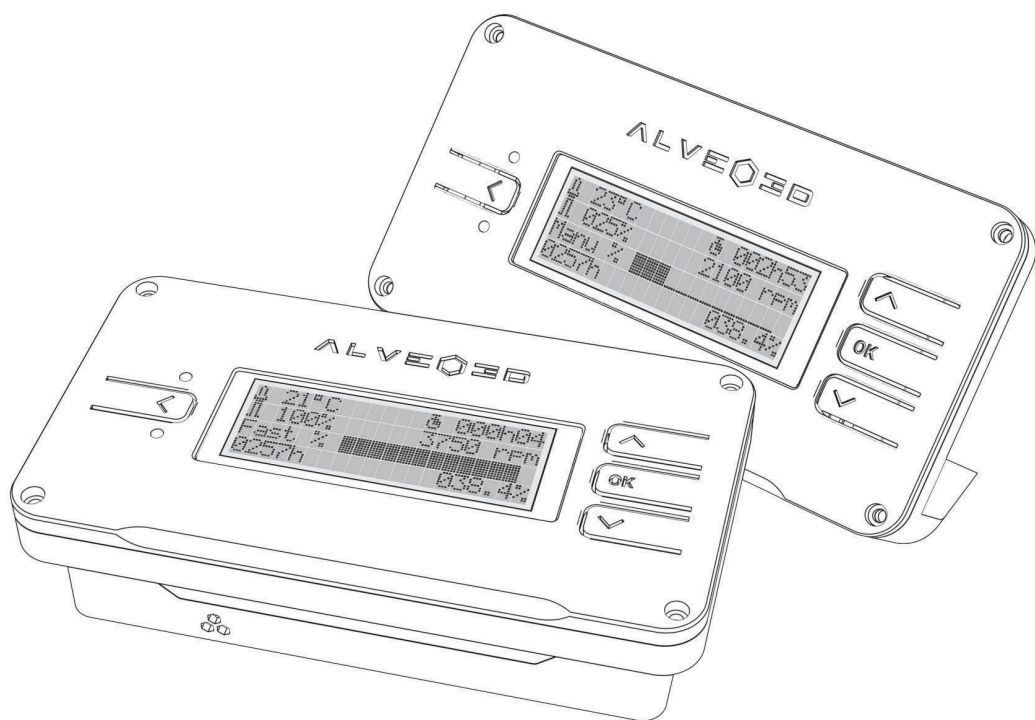

Find all our tutorials and tips

www.alveo3d.com/en/board-v2-assembly/

ALVEO3D

v1.1 EN

ELEMENTS PROVIDED

Elements included in the board v2 package

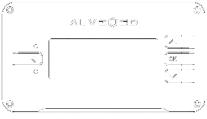

- Electronic board v2

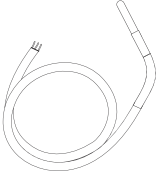

- Temperature probe length 90 cm

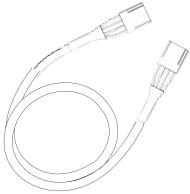

- Power supply wire from v1 to v2 length 90 cm



- Cylindrical screw M3 20mm x4



- Hexagonal nut M3 x4

Tool needed



- Hexagonal key 2.5 mm

SUMMARY

SECURITY	p. 1
COMPOSITION BOARD V2	p. 2
CONNECT V2 TO V1	p. 3
ACTIVATION : START SCREEN	p. 4
STEP 1 - MAIN INFORMATION	p. 5
STEP 2 - MODES	p. 6
STEP 3 - FAST CLEAN MODE	p. 7
STEP 4 - MANUAL MODE	p. 8
STEP 4 - MANUAL MODE	p. 9
STEP 5 - AUTOMATIC MODE	p. 10
STEP 5 - AUTOMATIC MODE	p. 11
STEP 5 - AUTOMATIC MODE	p. 12
STEP 6 - EDIT PROFILES	p. 13
STEP 6 - EDIT PROFILES	p. 14
STEP 7 - FILTER INITIALIZATION PROCESS	p. 15
STEP 8 - END OF FILTER INITIALIZATION PROCESS	p. 16
STEP 9 - FILTER INFO & PROFILES REINITIALIZATION	p. 17
STEP 10 - OPTIONS V2	p. 18
STEP 11 - LEDS & ERRORS	p. 19
STEP 11 - LEDS & ERRORS	p. 20

Read the conditions of use :

- The electronic board v2 is designed to work with alveoONE filtering kits. If you used the board v2 with other devices than recommended, no responsibility can be accepted in case of system malfunction.
- The electronic board v2 (version 2.1 or more) is powered by the alveoONE filtering electronic board v1 (version 1.3 or more). You must switch on the filtering box to run the electronic board v2.
- The board v2 is delivered printed and assembled. In the case of opening by the user, all damage will be under his responsibility.
- The recommended operating temperatures of the board v2 are from 0°C to 50 °C in an enclosure. Beyond this temperature, we recommend using the electronic board v2 outside of the enclosure.
- While the fan is running always make sure the grid is on the filtering box to avoid danger from the blades.

COMPOSITION BOARD V2

The board v2 is provided and assembled with the power wire and temperature probe.

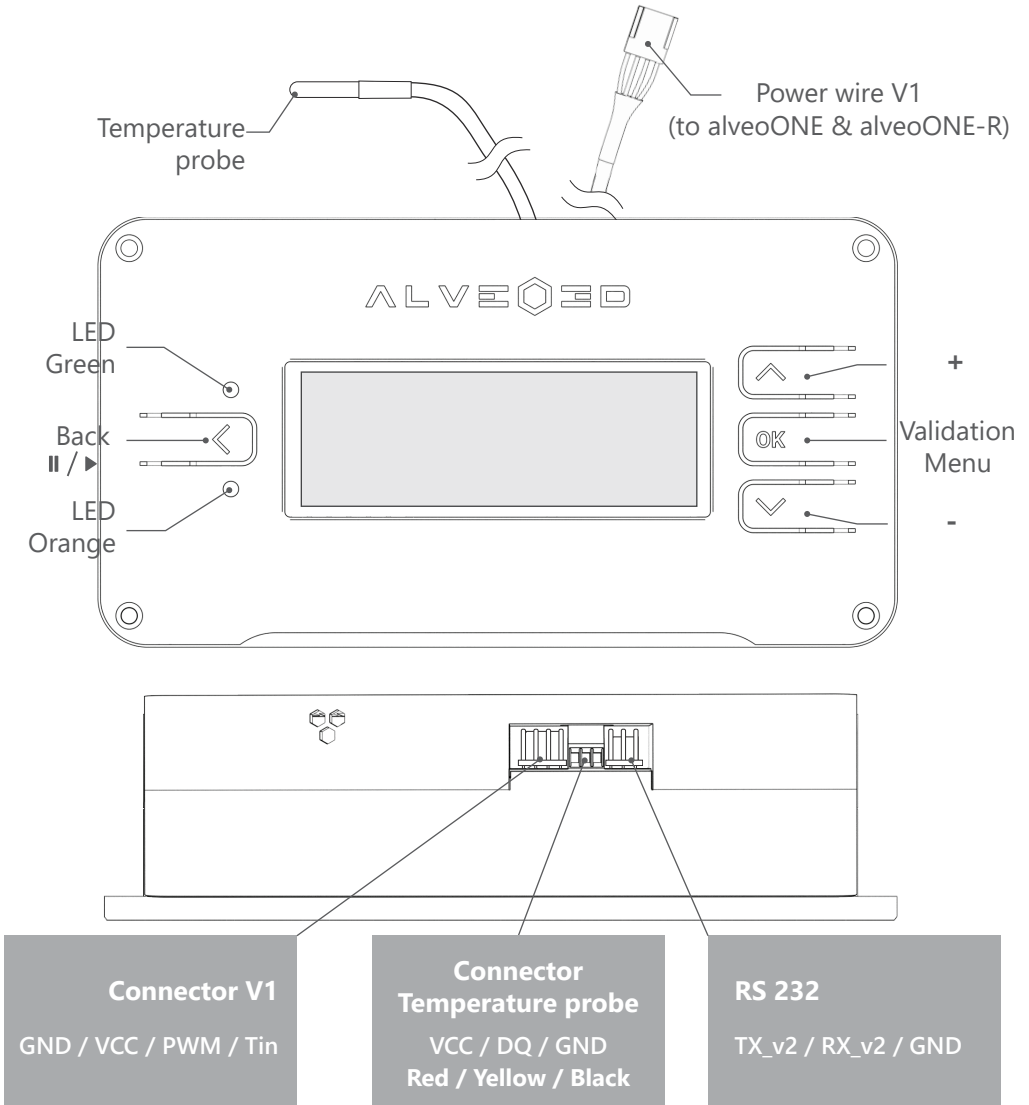

find board V2 tutorials on :
www.alveo3d.com/en/tutorial-v2/

CONNECT V2 TO V1 ON THE ALVEOONE

Connect the 4 pins cable provided on the v1 connector called BOARD V2.
The electrical supply comes from the v1 board, you shall turn it on to feed the v2.

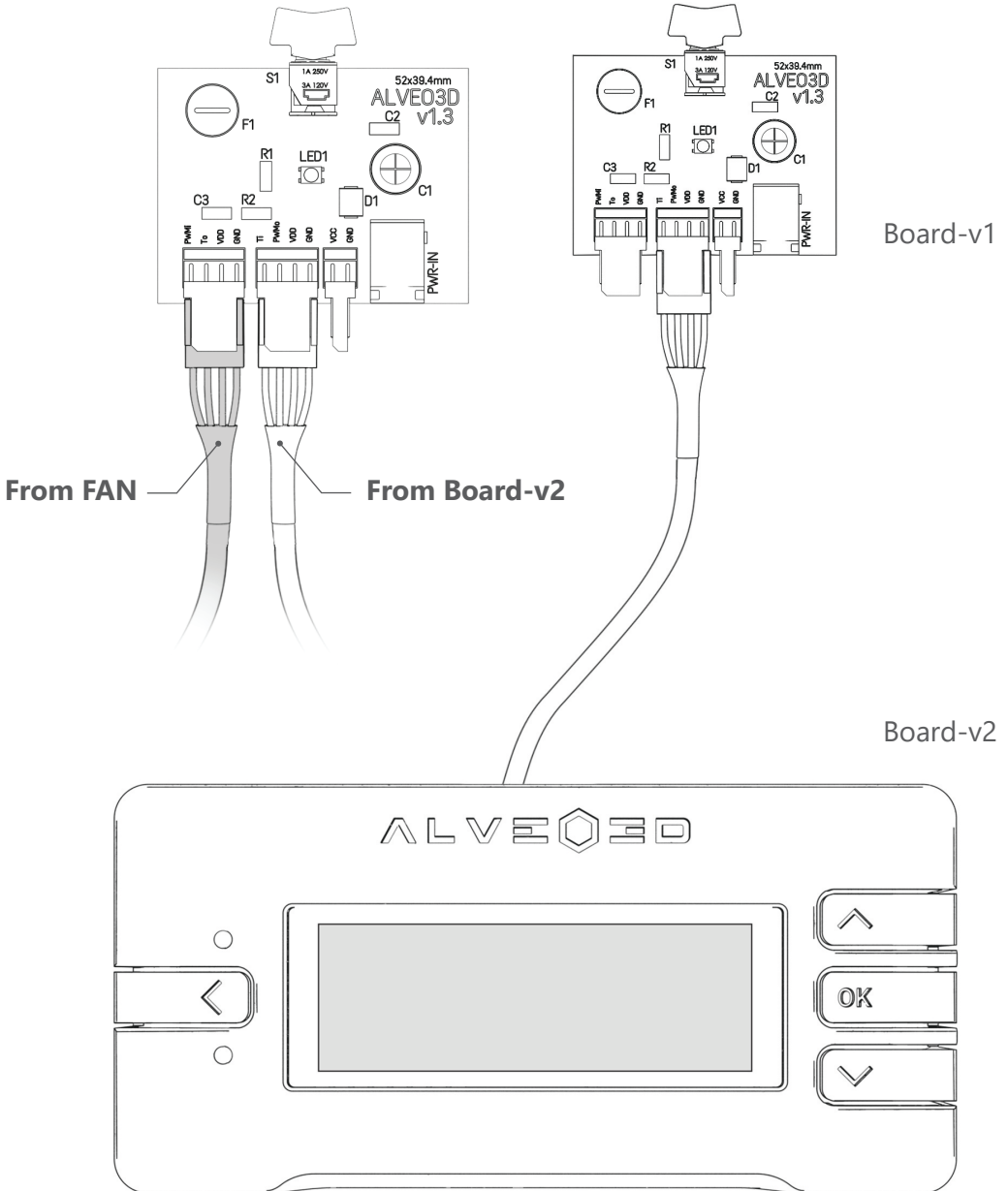

ACTIVATION : START SCREEN

To turn on the board v2, the filtering box switcher must be turned on as well. The loading screen appears while all sensors and systems are initiating.

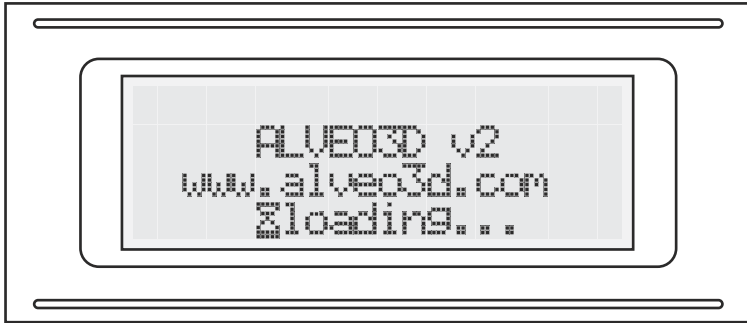

FIRST LAUNCH



At the first launch, the board v2 will require an initialization process. (see page 15 for the initialization process)

After this step, the board v2 is ready to use, you can start to use it now.

At the first use, select the language with OK. English and French are available, if you choose the wrong language you can change in the option (p.18).

STEP 1 - MAIN INFORMATION

When the device is turned on, the screen displays the main information and it waits for mode selection before to start.

Find the board v2 tutorial video on :
www.alveo3d.com/en/board-v2-assembly/

Main information

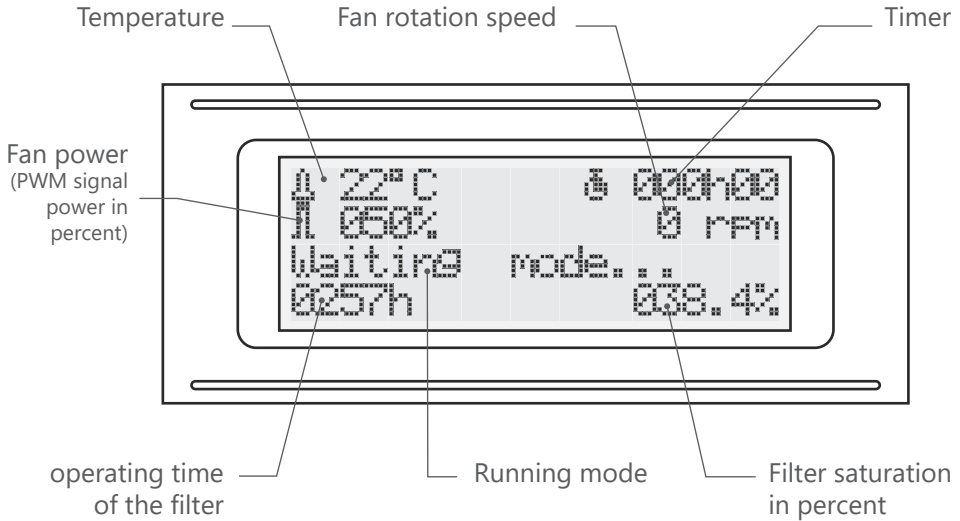

Main information

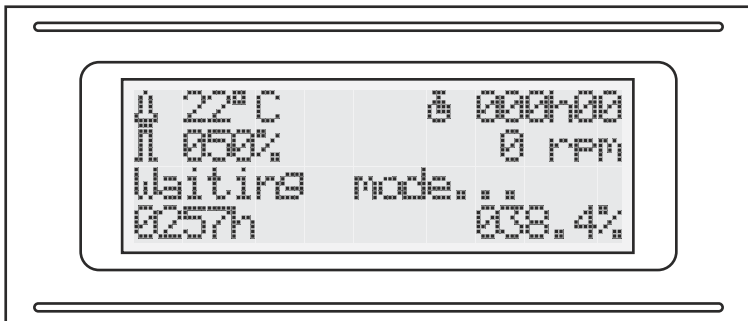

STEP2 - MODES

To access to the modes in the main menu, press OK on the main screen

Main menu: all modes

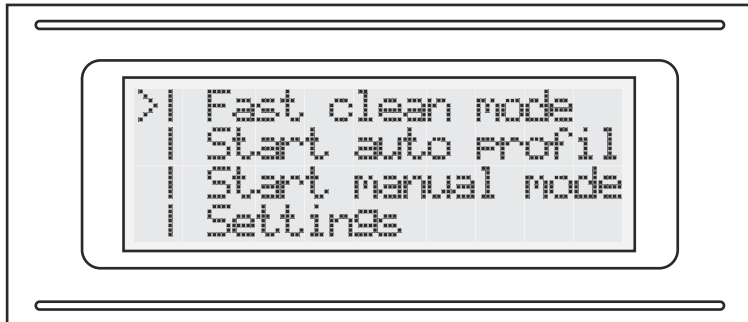

#1 Fast clean mode

«Fast clean mode» is designed to clean up your enclosure air as fast as possible. With the enclosure air volume that you defined during the initialization step, the board v2 calculates the best timing to renew the air. The fan speed is running at 100 % power in this mode.

#2 Start auto profile

«Start auto profile» for automatic speed fan profiles with unique features that you can edit to create your own profiles.

#3 Start manual mode

«Start manual mode» is the manual mode to let you control the fan speed.

#4 Settings

«Settings» to access the board v2 parameters :

- Edit or reinitialize profiles
- New filter initialization
- Check filter and board details

STEP 3 - FAST CLEAN MODE

The fast clean mode turns on the fan at 100% speed during the time determined by the volume of your enclosure : this mode is designed to clean the air as fast as possible before an operation inside the enclosure.

Main menu : Select fast clean mode

Select the mode with the button OK

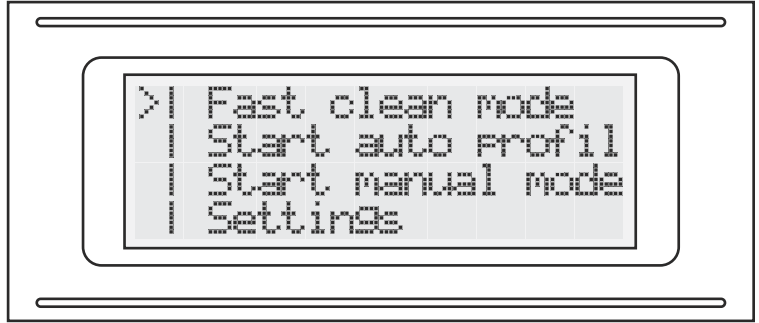

The fast clean mode is active during a short calculated to ensure optimum air renewal.

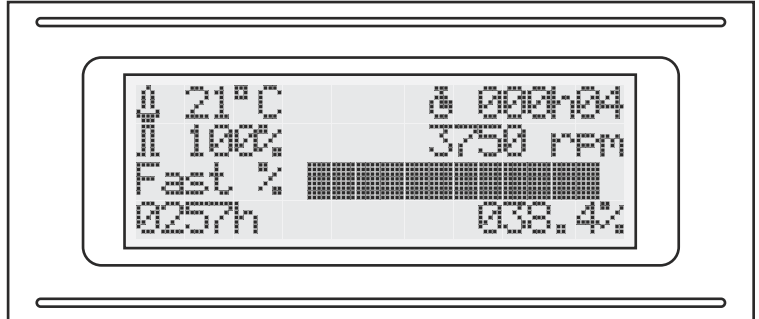

The button «BACK» can pause the mode whereas «OK» can stop it or to access the parameters

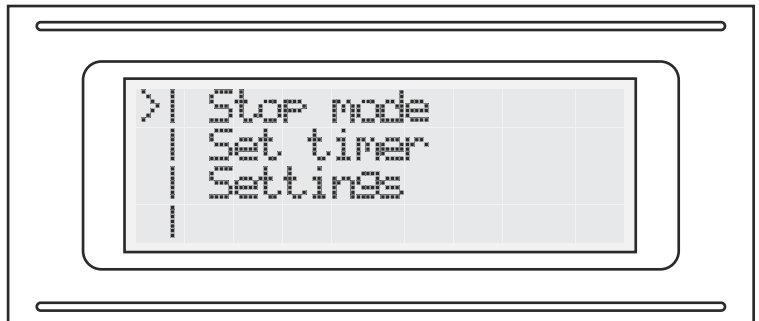

STEP 4 - MANUAL MODE

Control the fan speed and duration with the manual mode

Main menu : select the manual mode

Mode selection
with « OK »

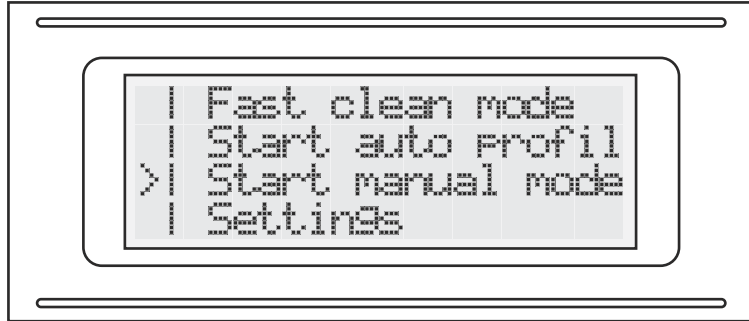

Choose filtration
time needed
with buttons
- and +



To reset the timer to zero faster, press buttons
- and + together in the same time.

STEP 4 - MANUAL MODE

After the setting time, the manual mode main menu appears : the bar graph shows the fan speed.

Manual mode setting

Power settings with - and + buttons in real-time

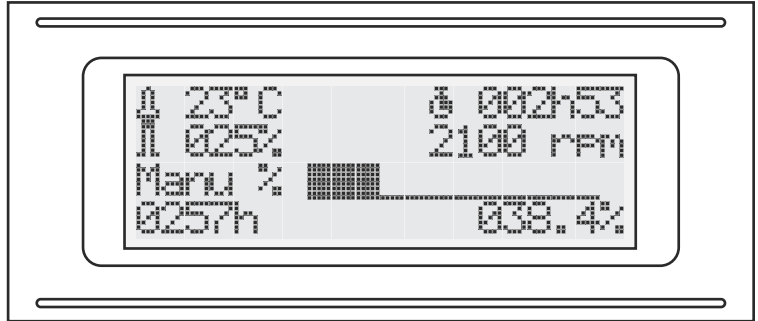

Click on Back to stop the mode or on OK to access to parameters

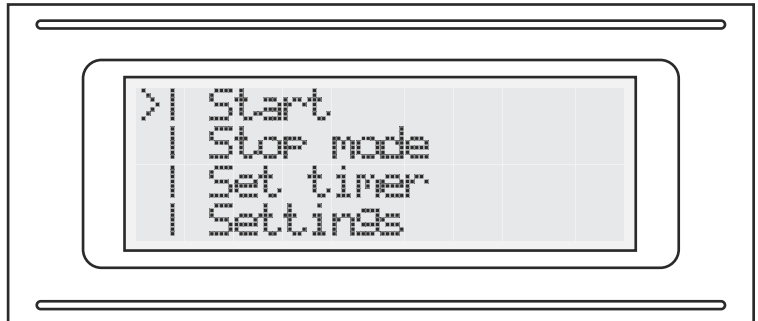

Modify the remaining fan operating time with Set timer

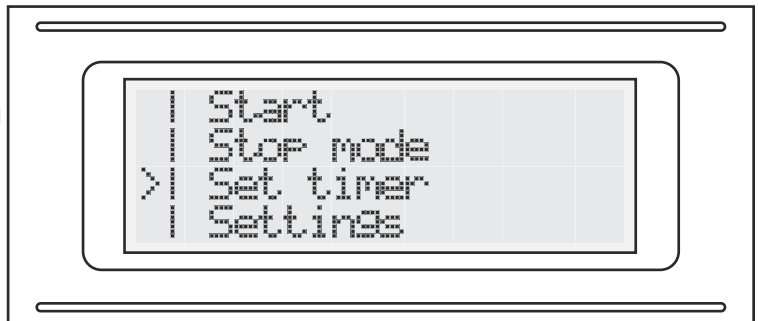

STEP 5 - AUTOMATIC MODE

Profiles can adjust the speed of the fan automatically. That can help to change the temperature in the enclosure or reduce the fan noise.

Main Menu : selection automatic mode

Automatic mode profiles can be edited

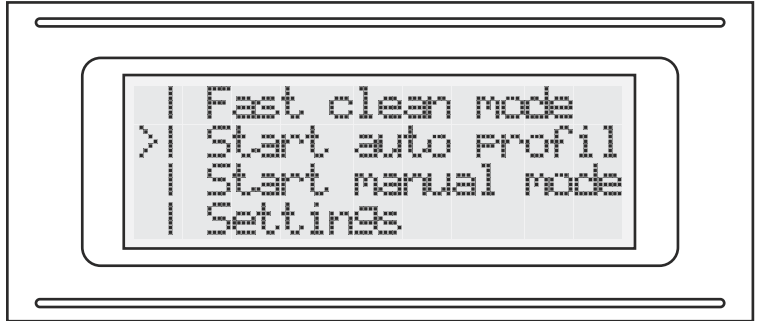

Select automatic mode with + and -



Start the profile with OK, this arrow shows the current selected profile



STEP 5 - AUTOMATIC MODE

After the profile selection, duration should be defined if you wish an automatic fan stop.

Automatic mode settings

We recommend to define the profile duration on the printing time.

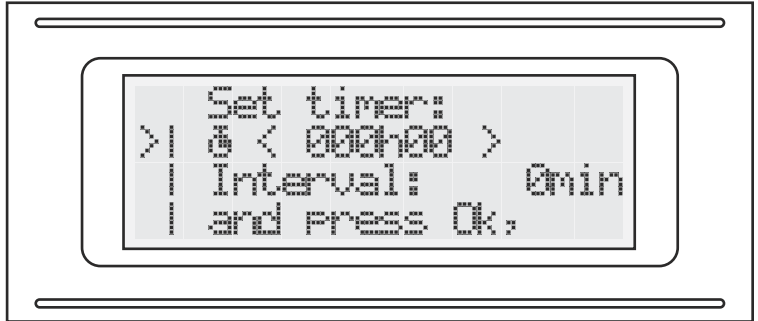

Change duration with + and -. The interval is the time of each profile sections.

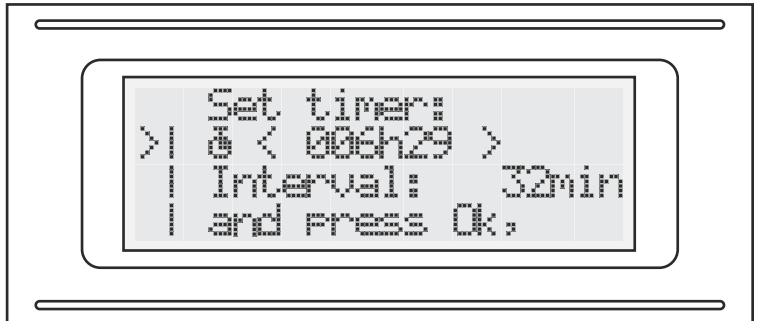

Press Ok to start profile

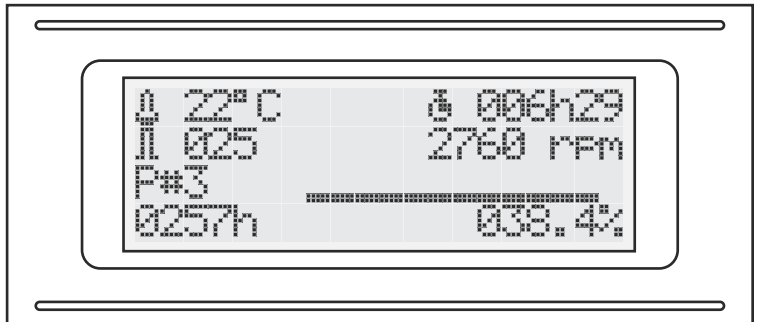

STEP 5 - AUTOMATIC MODE

3 automatic modes are available.

Automatic mode : details

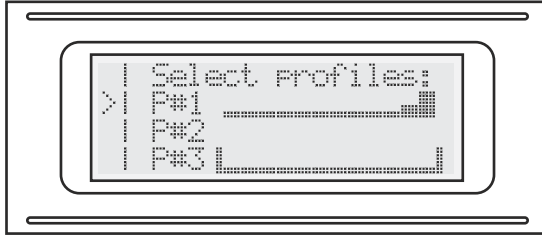

Profil #1 : standard

Fan speed
(PWM signal
power)

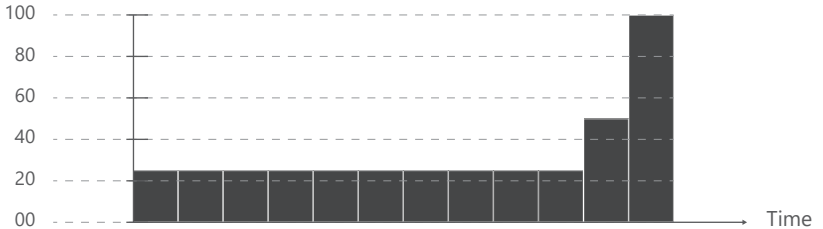

Profil #2 : free profile

Fan speed
(PWM signal
power)



Profil #3 : first 10 minutes 100% speed before profile start then automatic Fast clean mode at the end

Fan speed
(PWM signal
power)

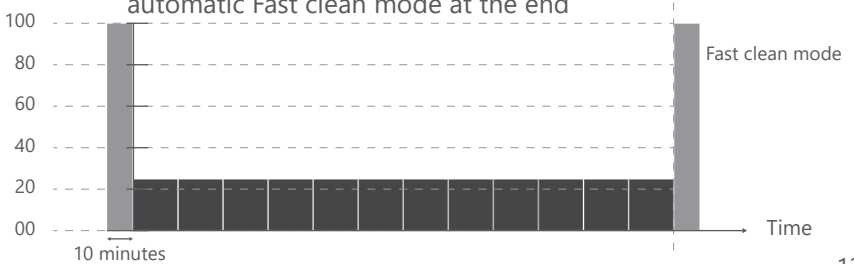

STEP 6 - EDIT PROFILES

To edit profiles go to the main menu / «Settings» / «Edit profiles». You can add new profiles, but you can modify the 3 existing profiles.

Edit profiles

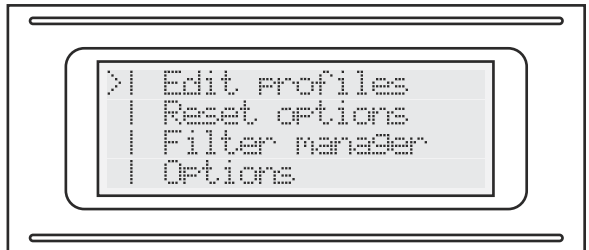
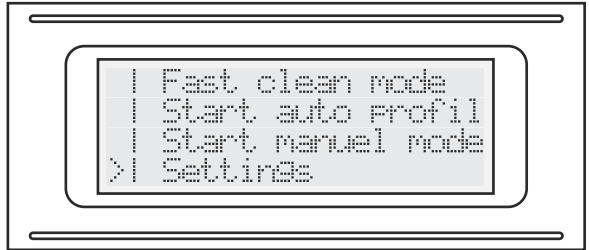

Select the profile to modify with the cursor  and press OK



There are 12 intervals show the total amount of running time. The cursor  indicates the interval to modify.

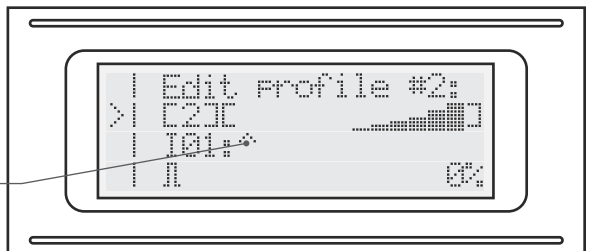



STEP 6 - EDIT PROFILES

Custom profiles can be created to suit your filtration needs.

Edit profiles

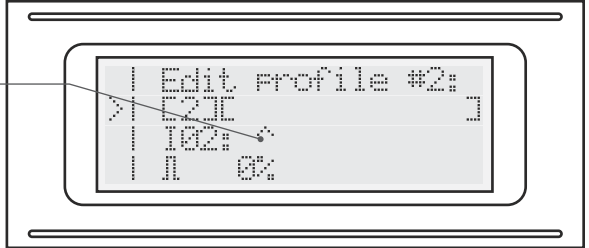
Press - and + to move the cursor  to select the interval to modify



Press OK to select the interval and the cursor change to 
With this cursor, you can modify the power of the interval with - and +



When you have done, press BACK then OK to validate and save the modification.

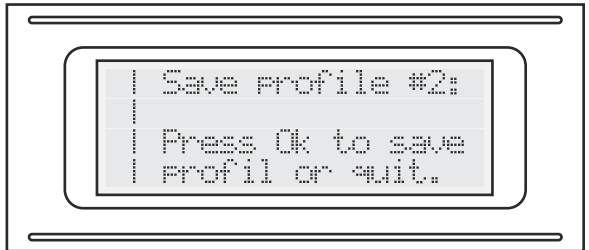

STEP 7 - FILTER INITIALIZATION PROCESS

Go to the main menu / «Settings». We always recommend doing the initialization process with a new filter.

Filter initialization

To access the initialization process, go to «Settings» / «Reset option» / «Reset filter»

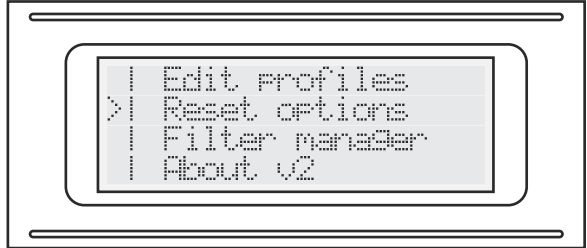

If you think to access the initialization process is not easy to find. It is to avoid mistakes.

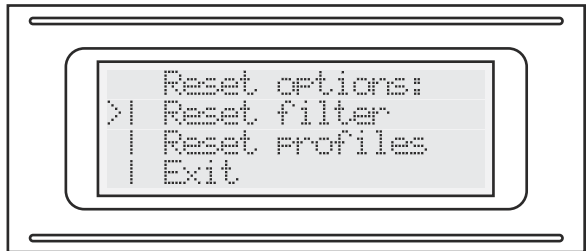

If you select «Reset filter» by mistake you can go back to the previous menu with BACK.

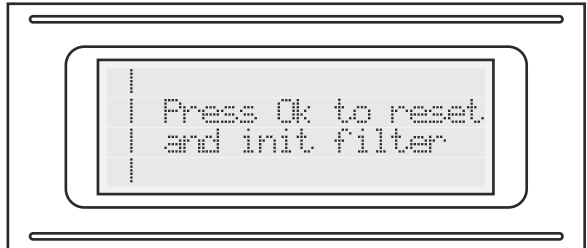

After the double confirmation, reboot the board V2, by pressing ON/OFF on the filter box alveo3D

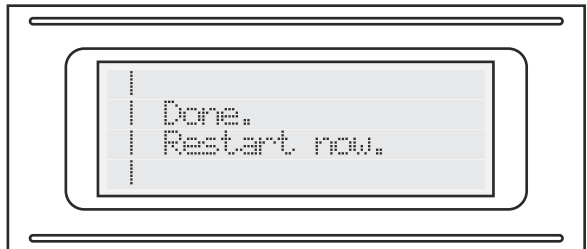

STEP 8 - END OF FILTER INITIALIZATION PROCESS

The process is automatic, just follow the instructions displayed on the screen. Be very careful the fan will run at 100% speed during the process.

Filter initialization

Always place the fan grid in position before to run the fan.

Choose «YES» if you use a new filter.

Choose «No» if your filter is not new.

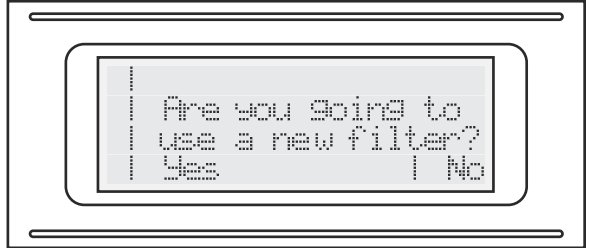

If you use a new filter.

Remove the old filter, take precautions with gloves and put the old filter in a sealed plastic bag.

The fan will start.

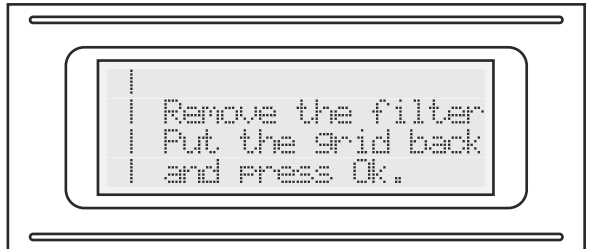

Caution do not touch the fan during the procedure.

The first step will take 20 seconds. Then press «Ok».

The second step will start. Follow the instructions then press «Ok».

With - and + set the size of your enclosure in dm³. After the filter initialization process, you will be redirected to the main screen.

Remettre la grille de protection

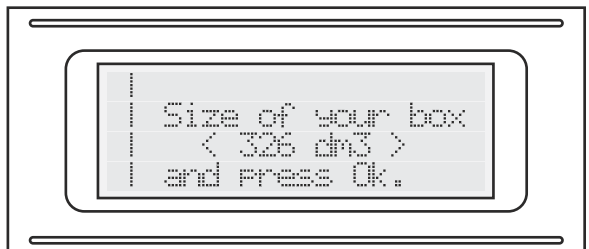

STEP 9 - FILTER INFO & PROFILES REINITIALIZATION

If you want to get the default settings, go to «Settings» / «Reset option» / «Reset profile»

Restore the default settings

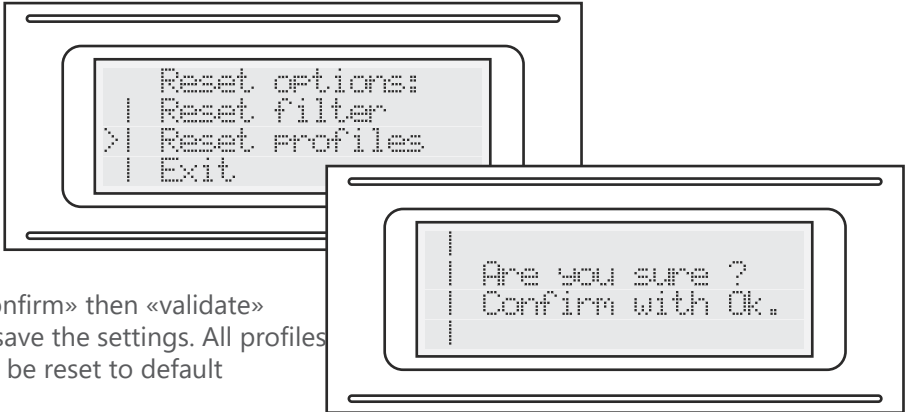

«confirm» then «validate»
to save the settings. All profiles
will be reset to default

See the filter information

Go to «Settings» / «Filter
manager» to see all filter
information

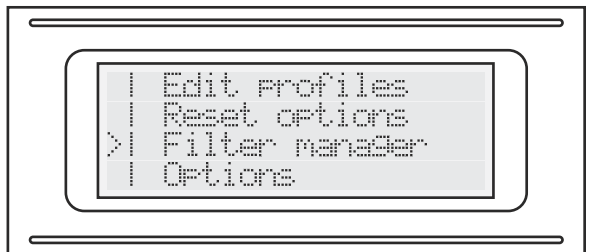

Time : cumulated time of the use
of filter

Filter : filter saturation

Time left : time remaining before
saturation

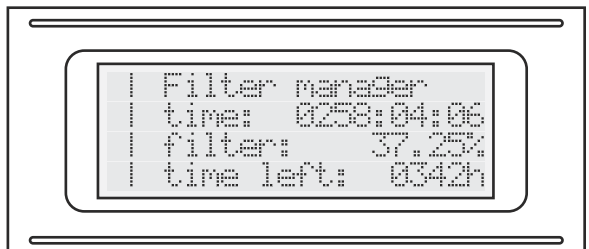

STEP 10 - OPTIONS V2

Set Options

Go to «Options» to change parameters

Use + and - button to select the option and «OK» to change it.

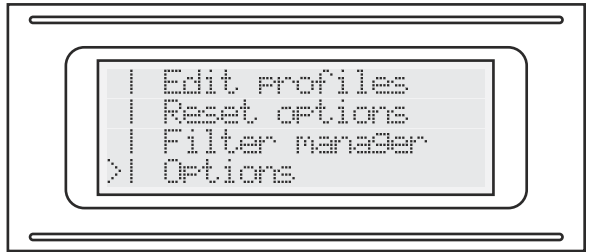

#1 Lang:

Change the language
EN is English / Fr is French

#2 Buzzer:

Enable or disable the buzzer
Not available on this version

#3 Backlight:

Enable or disable the backlight
If enabled the screen backlight will turn off after 60 sec of inactivity.

#4 Fan 3000 Rpm:

Change the algorithm to calculate the fan speed
Only recommended for the fan model BLHP24xx-xx
Keep it «off» for the fan ALHP2425-H8

#5 Dbl extruder:

Change the algorithm for the use of the filter
Enable it only if your printer has 2 Hotends or if you have 2 printers in your enclosure.

#6 Rs232:

Enable or disable the Rs232 port (for remote control)
Our tutorial here : <https://www.alveo3d.com/en/tutorial-v2/>

#7 Opt #1:

Enable or disable TTL output 1
Not available on this version

#8 Opt #2:

Enable or disable TTL output 2
Not available on this version

STEP 11 - LEDS & ERRORS

How alveo3D V2 LEDs work :

Green LED : the fan is working
Orange LED : error / action

At the start (Power ON) :

The green LED is lighting. (it confirms LED work.)
 The orange LED lights up and blinks (it confirms LED works, and board v2 is busy.).

During the filter initialization :

STATUS	1	0	0-1-0-1
Green LED :	The fan is rotating	Fan stops	
Orange LED :	Action is in progress or not done yet	Waiting	
MENU PRINCIPAL :			
Green LED :	Current cycle The fan is rotating	Stop cycle Fan stops	Cycle in pause
Orange LED :	An error had been found. RPM, filter, temperature...	No error	
EDIT PROFIL :			
Orange LED :	Edit the interval selected in %	Select an interval section, with +/-	

STEP 15 - LEDS & ERRORS

Errors list :

During the initialization phase :

Error #1 :

Error, the fan is rotating under the expected speed :
The filter is probably not removed from the box.
> Remove the filter.

Error #2 :

Error, fan speed is zero.
The fan is disconnected or out of order or Tachymeter is out of order.

Error #3 :

The fan speed is lower than expected.
The fan is not working properly.
Or the board v2 is damaged.

Error #4 :

Error, the fan is rotating upper the expected speed :
The filter is probably missing.
> Put the filter.

On the MAIN MENU :

Temperature :

__°C : The prode is disconnected

85°C : At launch if temperature shows 85°C :

Temperature probe initialization error.

Wait for the probe to refresh the temperature (about a minute)
every minute.

On the menu ABOUT V2

on the second menu :

rpm#1 = error

Show an error during the initialization.
During the fan speed calculation
WITHOUT the filter.

rpm#2 = error

Show an error during the initialization.
During the fan speed calculation
WITH the filter.

BACK during initialization :

If an error shows up on the screen during the initialization you can restart the current step by pressing the button BACK.

NOTES :

A series of 20 horizontal dashed lines for writing notes.

NOTES :

A series of horizontal dashed lines for writing notes.

NOTES :

A series of horizontal dashed lines for writing notes.

NOTES :

Breathe ! you are filtering !

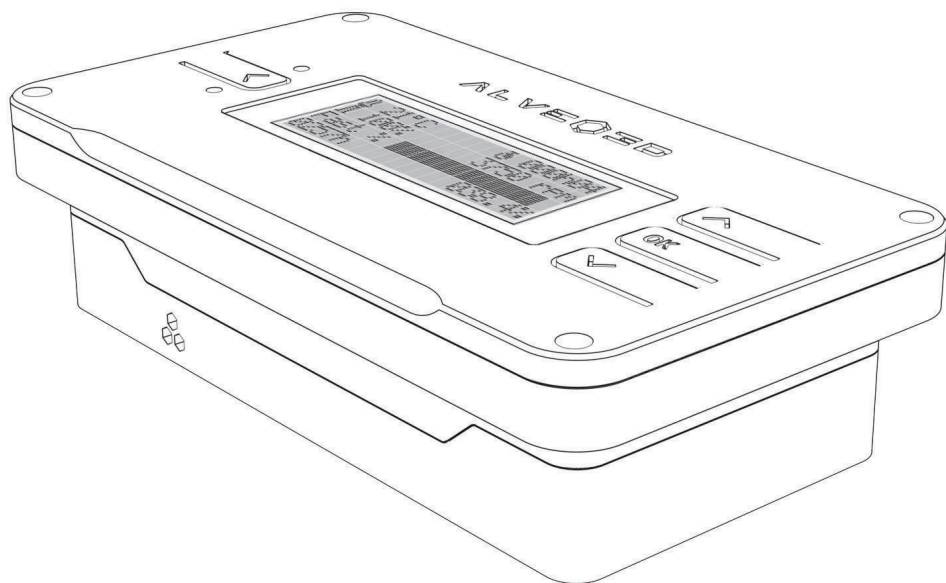

Share your experience on www.facebook.com/alveo3d/

ALVEO3D by
FLEXEE SYSTEM SAS
386 Rue de la Curiaz
73290 La Motte-Servolex
www.alveo3d.com
contact@alveo3d.com

Made in France
