

# INSTRUCTIONS MANUAL UPDATE ALVEOPRO2

ALVEO3D

## ALVEOPRO2 - M100

Filtering system for 3D printer - HEPA14 & active carbon

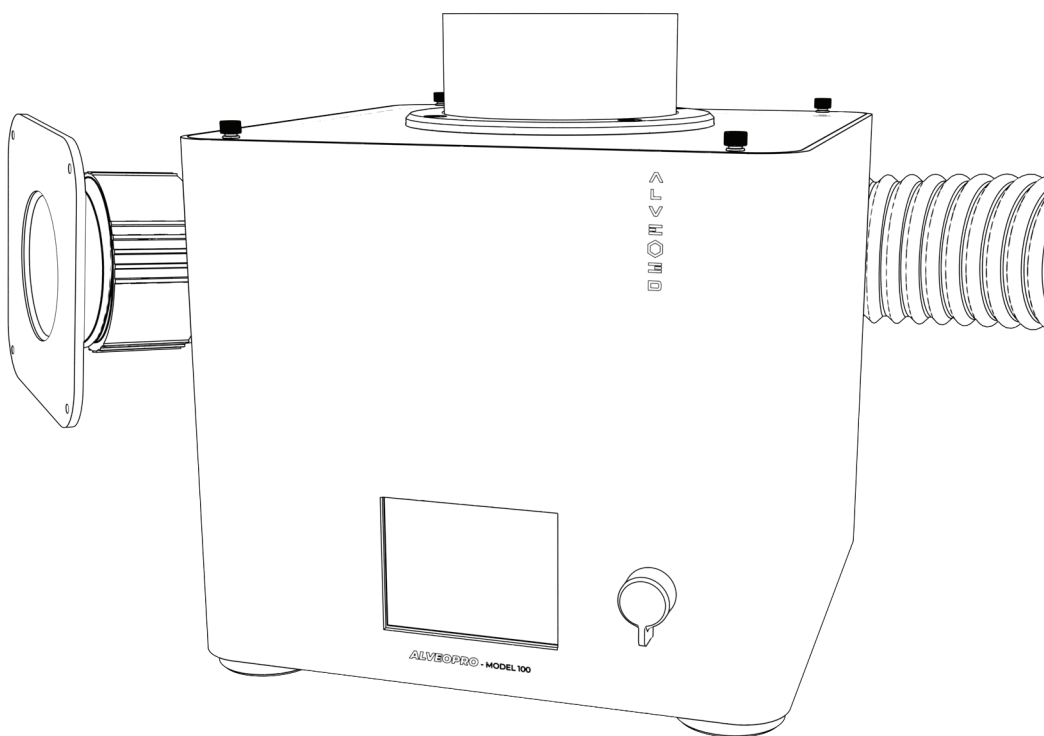

Find all assembly resources

[www.alveo3d.com/en/assembly-alveopro/](http://www.alveo3d.com/en/assembly-alveopro/)

and download contents

[www.alveo3d.com/en/download-alveopro/](http://www.alveo3d.com/en/download-alveopro/)

# POSITION OF THE ELECTRICAL SUPPLY

Connect the electrical supply directly to the electronic board. Use the anti-parasite guide and cable ties to facilitate the management of the power supply cable.

- 1.** Identify the locations for the cable ties and the guide.

Locations for cable ties

Anti-parasite guide

24V power connector

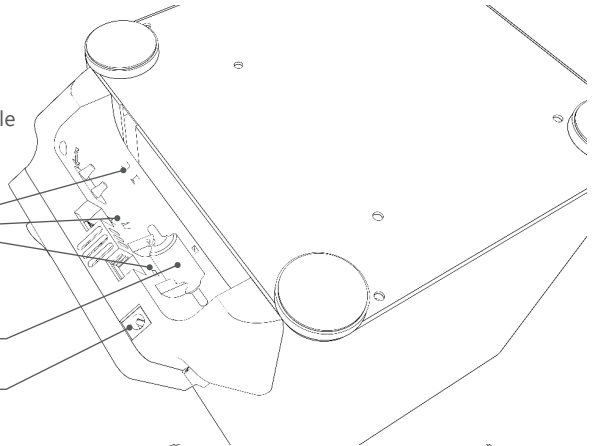

- 2.** Position the cylinder in the guide (apply a little force if necessary).

The cylinder in the guide should hold itself in place.

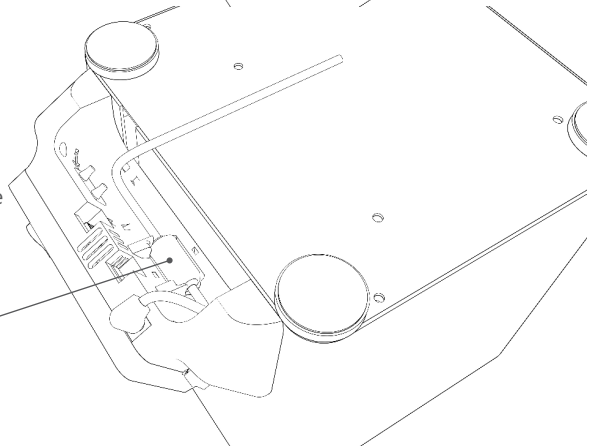

- 3.** Use the cable ties to hold the anti-parasite cylinder and the cable in position.

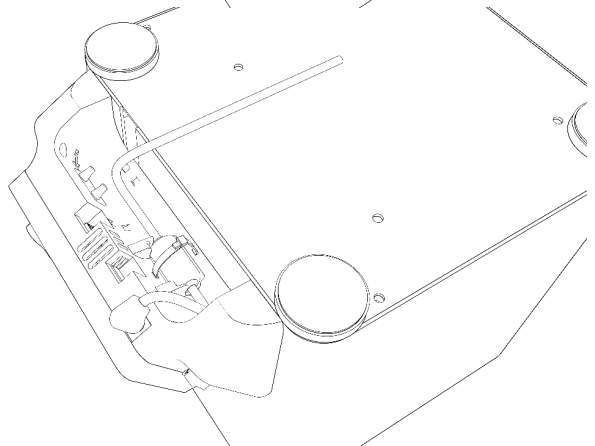

# AIR EXTRACTION SETUP

Replace the safety grille at the back of the AlveoPRO2 with the cylindrical connector with the flat edge. Position this connector so that the flat edge is facing down, then screw in the semi-rigid tube to manage the air extraction.

- 1.** Remove the protective grille.

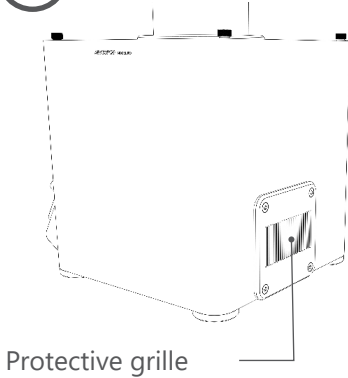

- 2.** Install the connector with the flat edge.

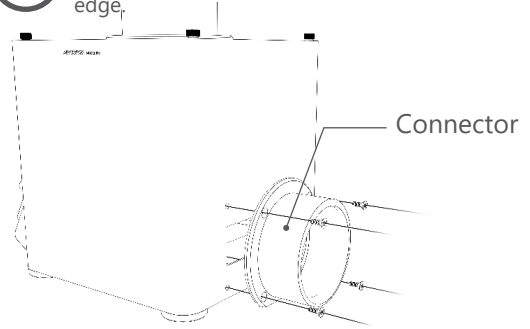

- 3.** Position the flat edge facing down.

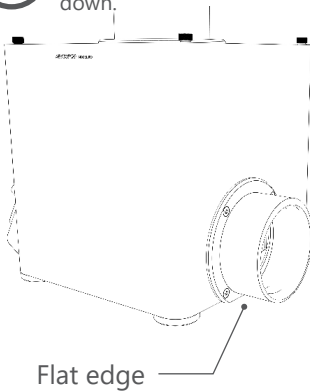

- 4.** Screw in the semi-rigid tube.

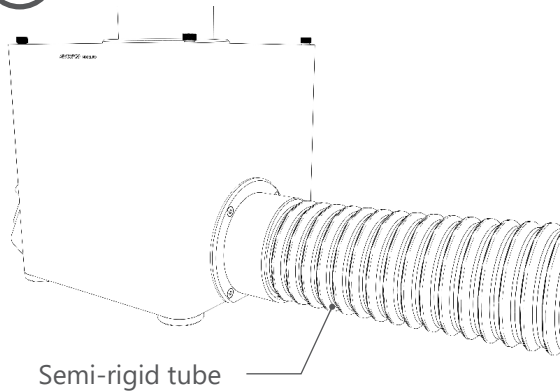

# NEW INTERFACE

30° tilt of the new interface

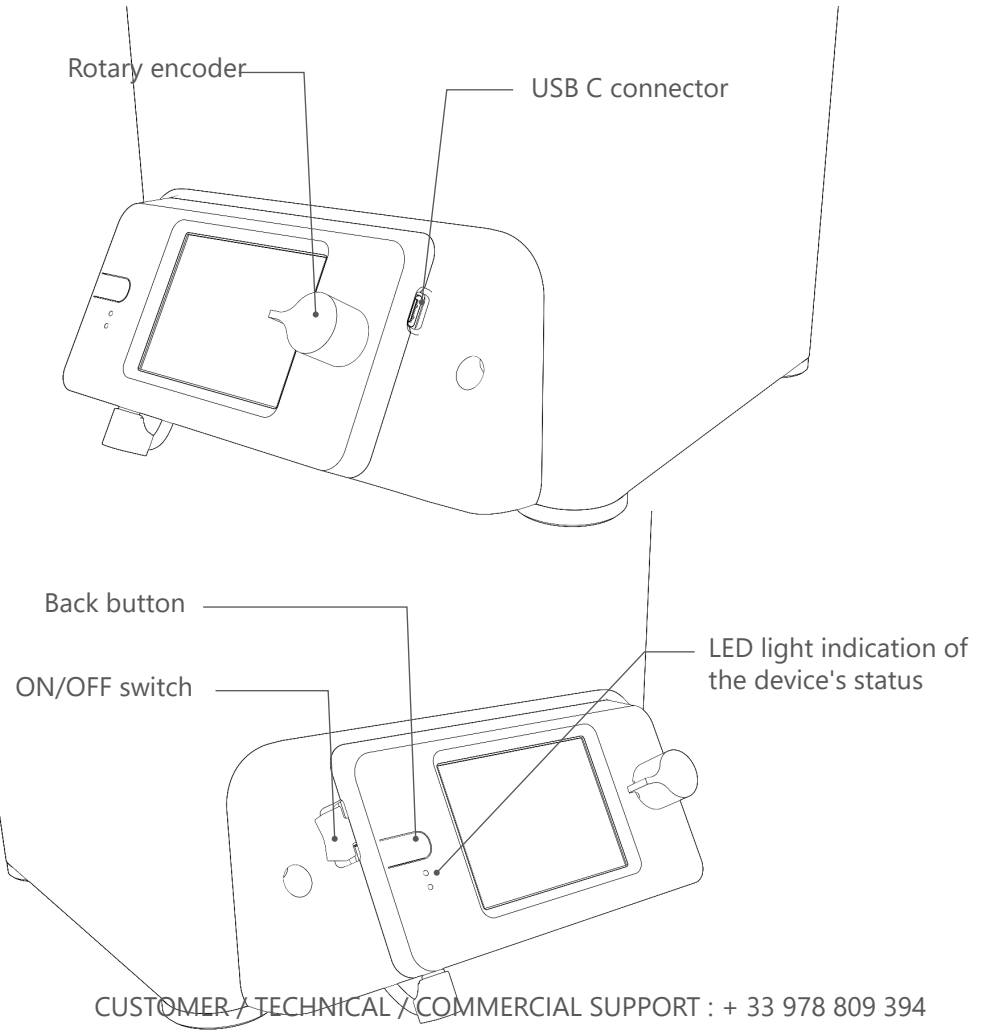

ALVEO3D by  
FLEXEE SYSTEM SAS  
460 Rue de la Leysee  
73000 Chambéry  
[www.alveo3d.com](http://www.alveo3d.com)  
[contact@alveo3d.com](mailto:contact@alveo3d.com)

**Designed in France**